

Hello!

- Visual comparison of Unix-like systems
- Mark SMITH <mhs@hp.com>
- Shanghai Hewlett-Packard, Dalian.

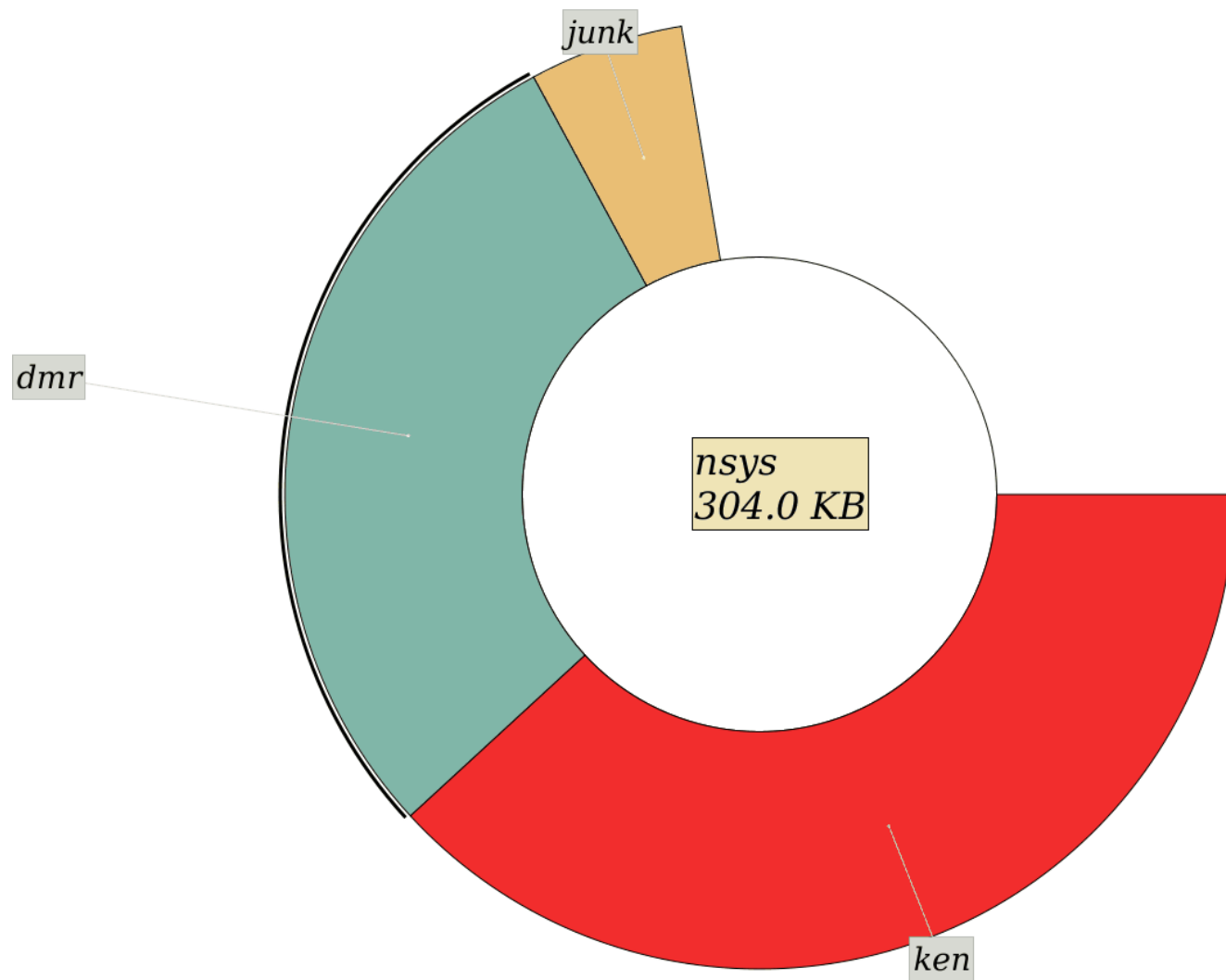

UNIX v3



UNIX v3

- Type: Monolithic
- Total source: 304KB
- SLOC: 6,015
 - C: 89.31%
 - asm: 10.69%

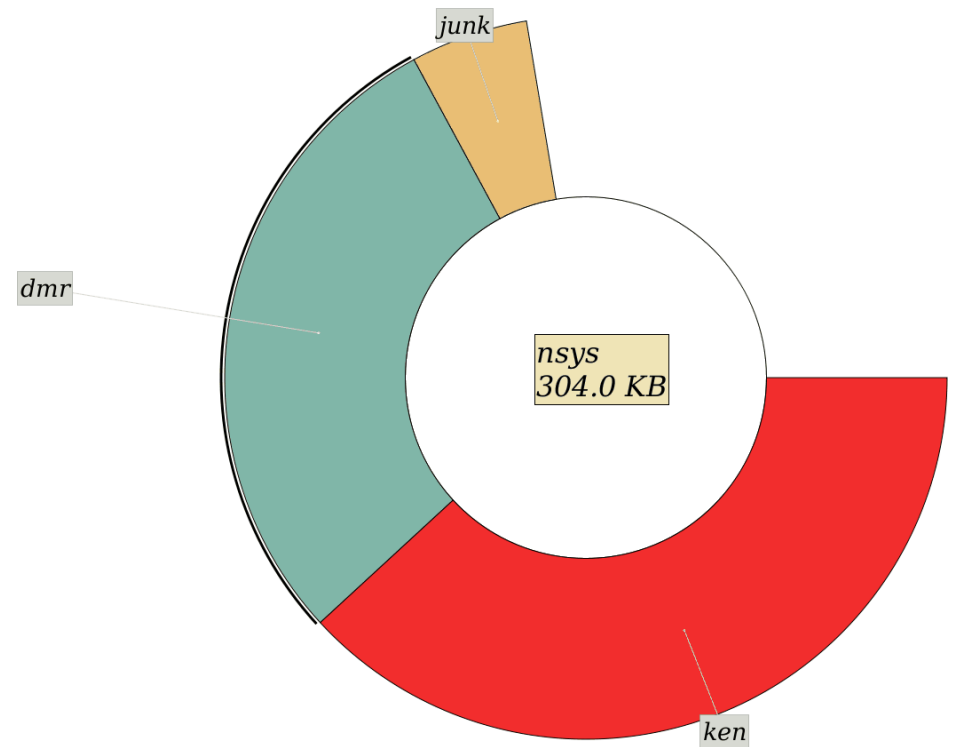

Plan9 kernel

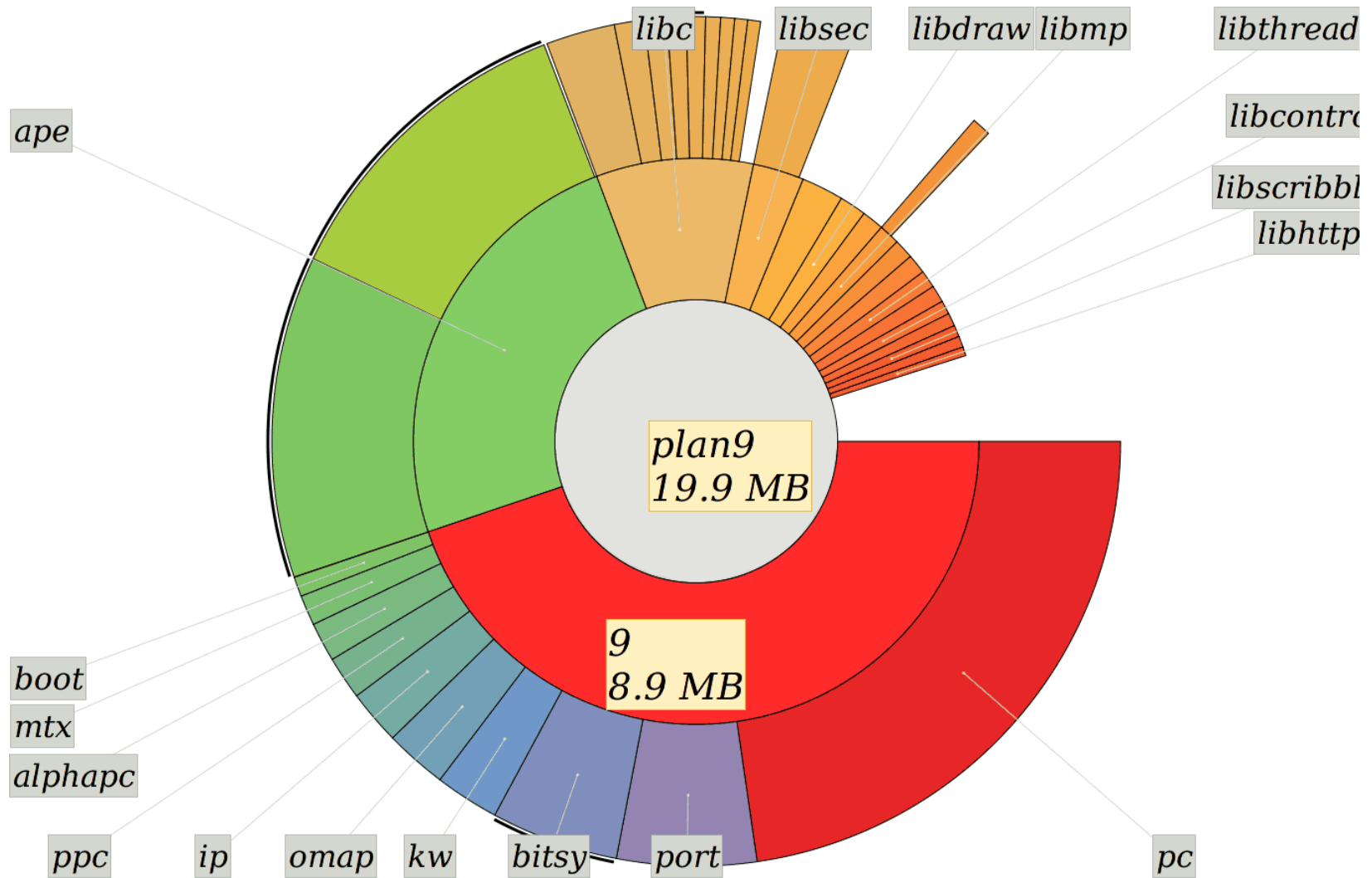

Plan9 kernel

- Type: Micro-like
- Total size: 8.9MB
- SLOC: 192,216
- C: 97.10%
- asm: 2.90%

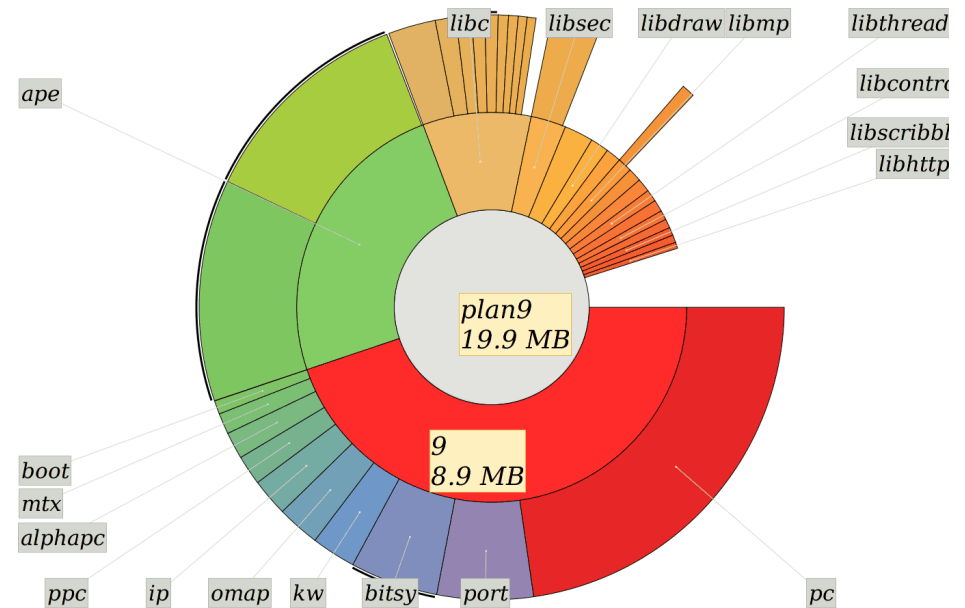

Microkernel architecture

Traditional (Monolithic) Kernel

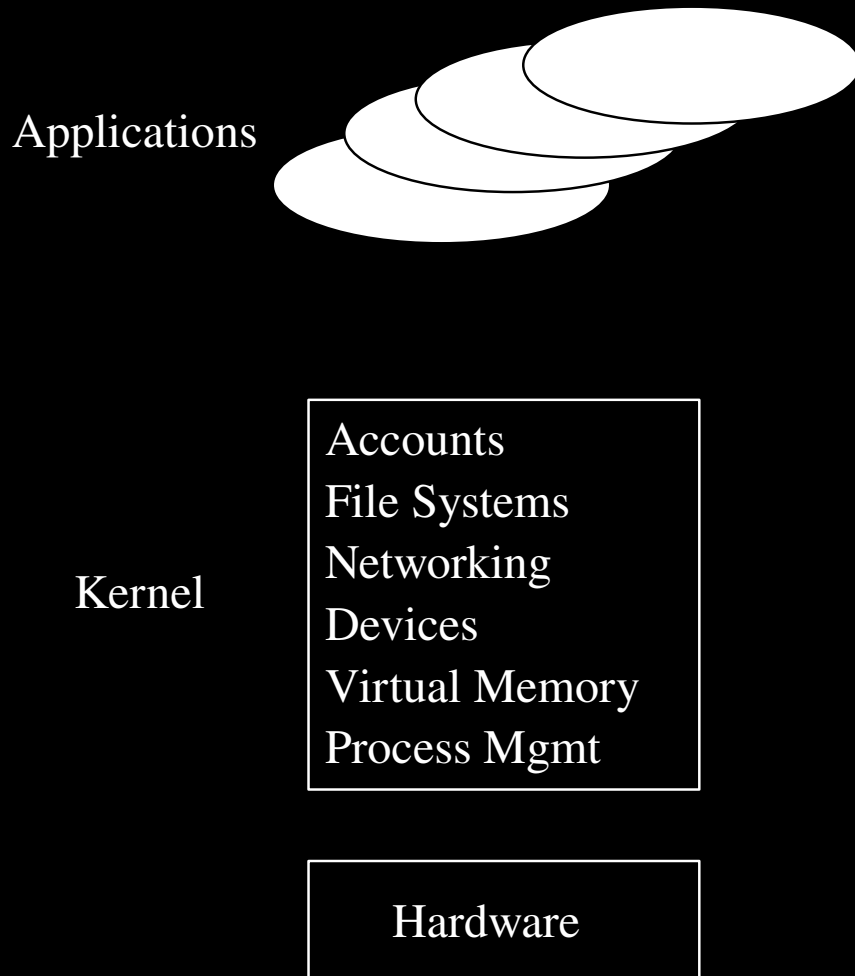

Microkernel

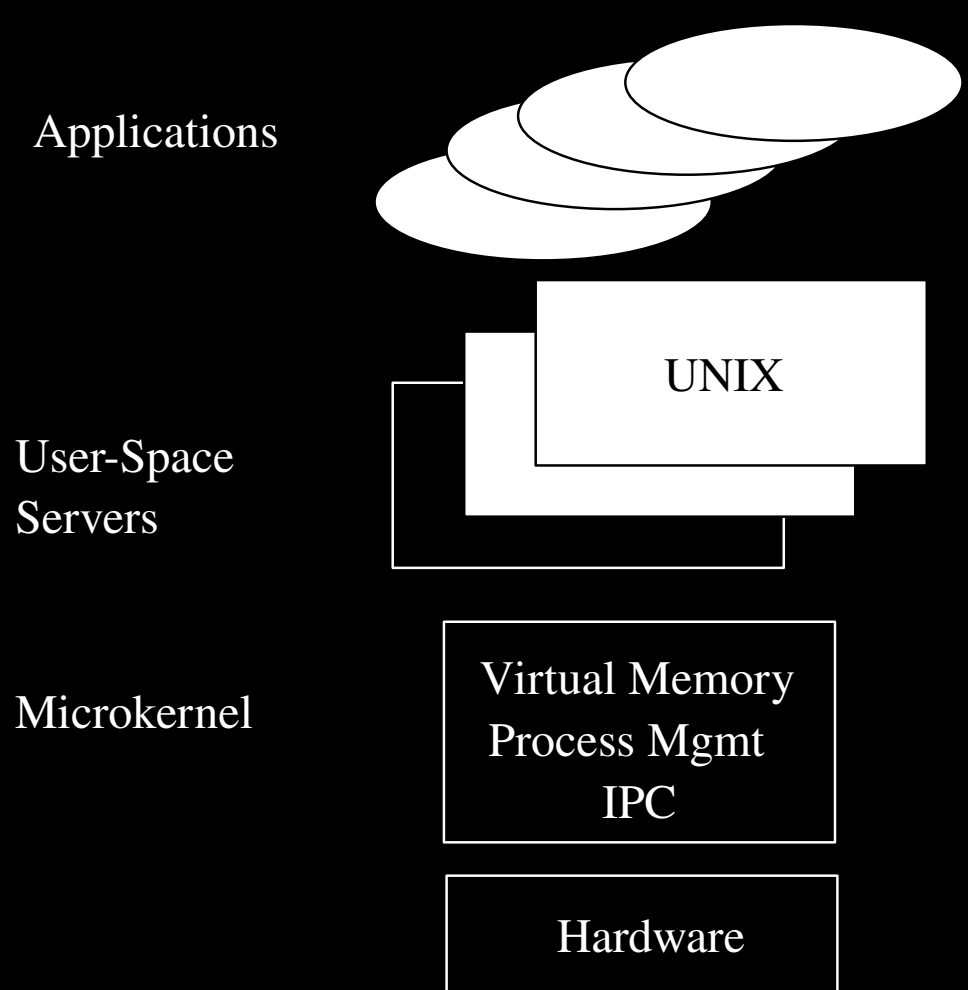

Minix kernel

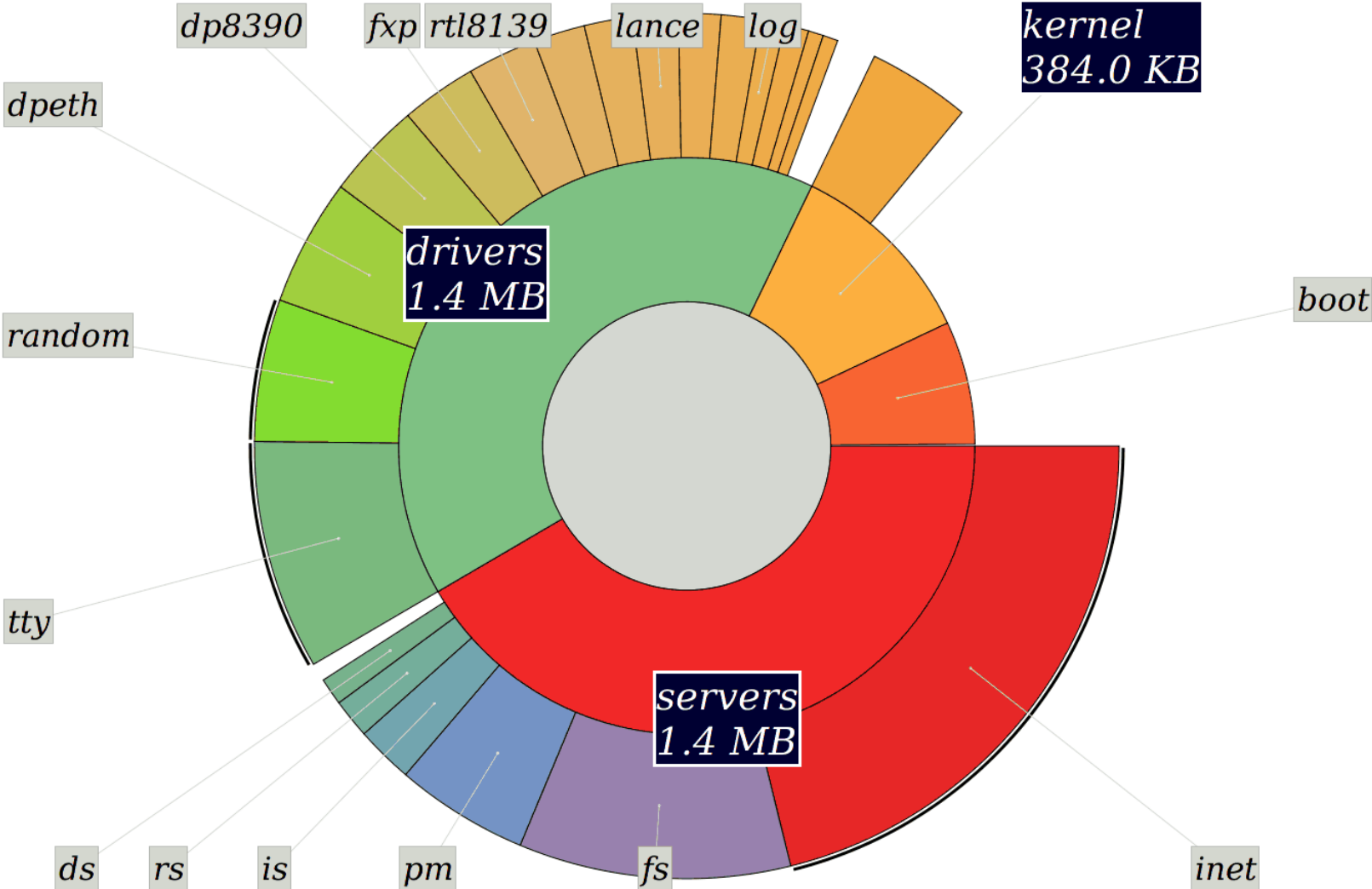

Minix kernel

- Type: Micro
- Total SLOC: 70,995
- C: 94.27%
- asm: 5.51%

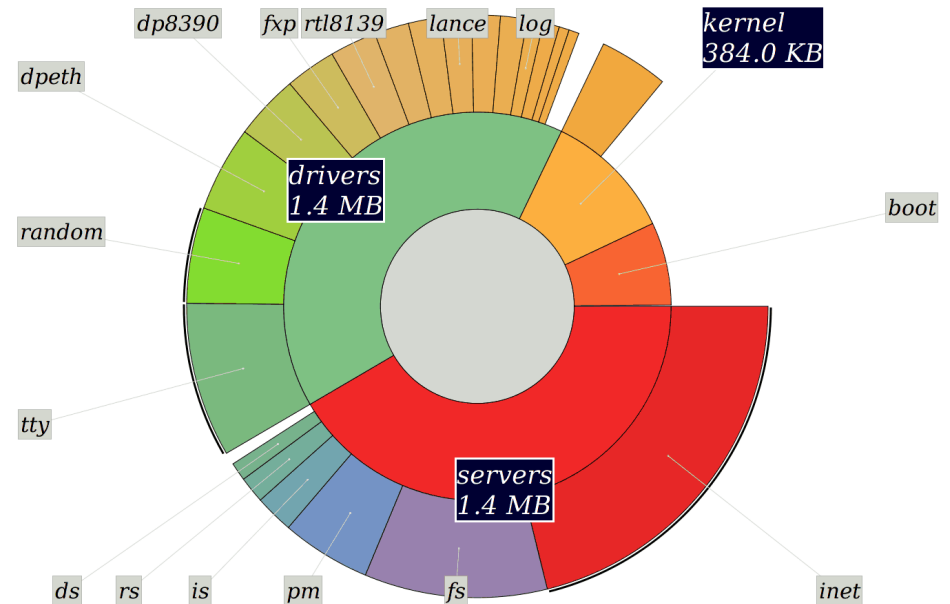

OKL kernel

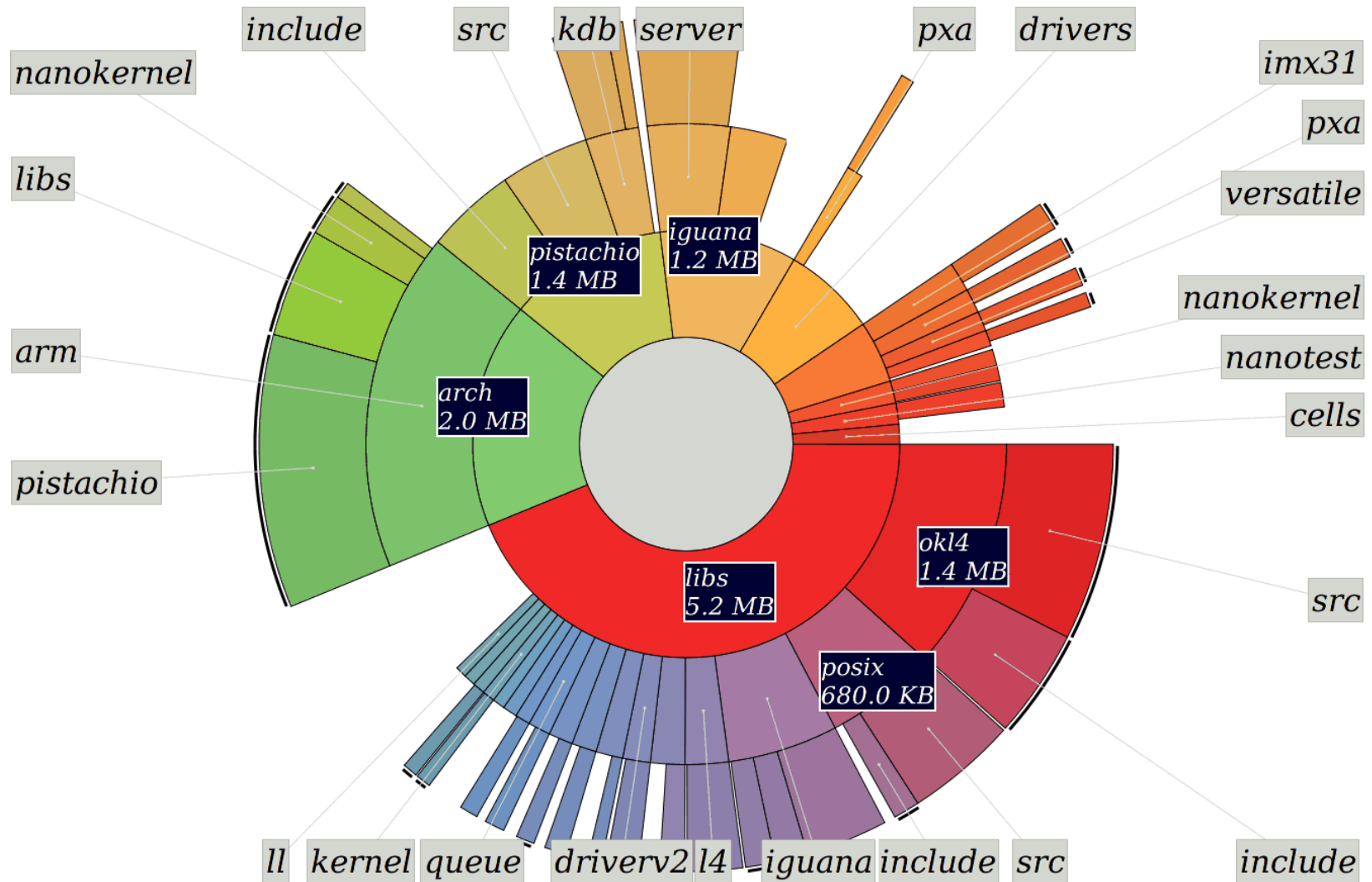

OKL kernel

- Type: Micro
- Total SLOC: 367,154
 - C: 151374 (41.23%)
 - cpp: 108125 (29.45%)
 - Python: 90939 (24.77%)
 - asm: 10917 (2.97%)

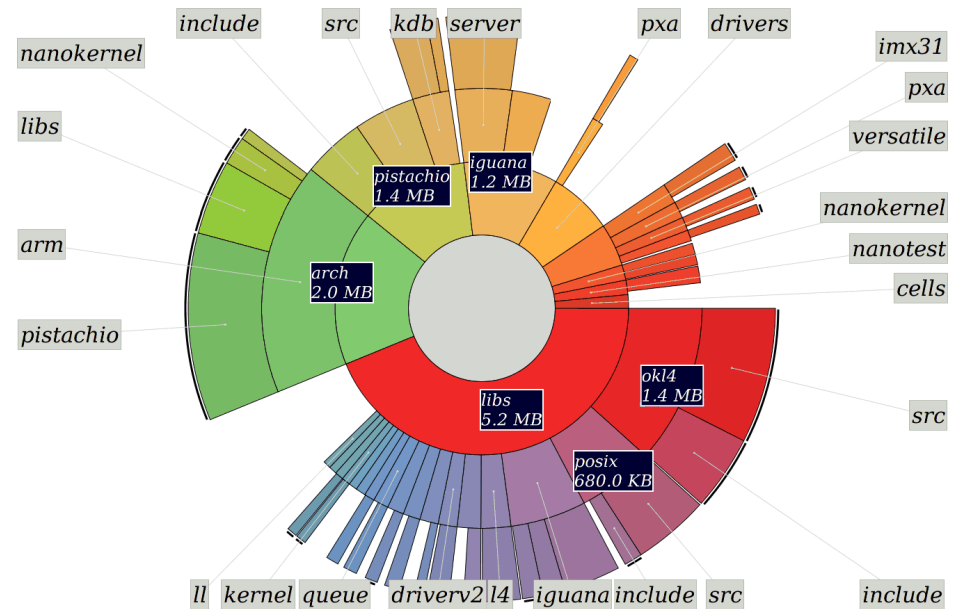

XNU kernel

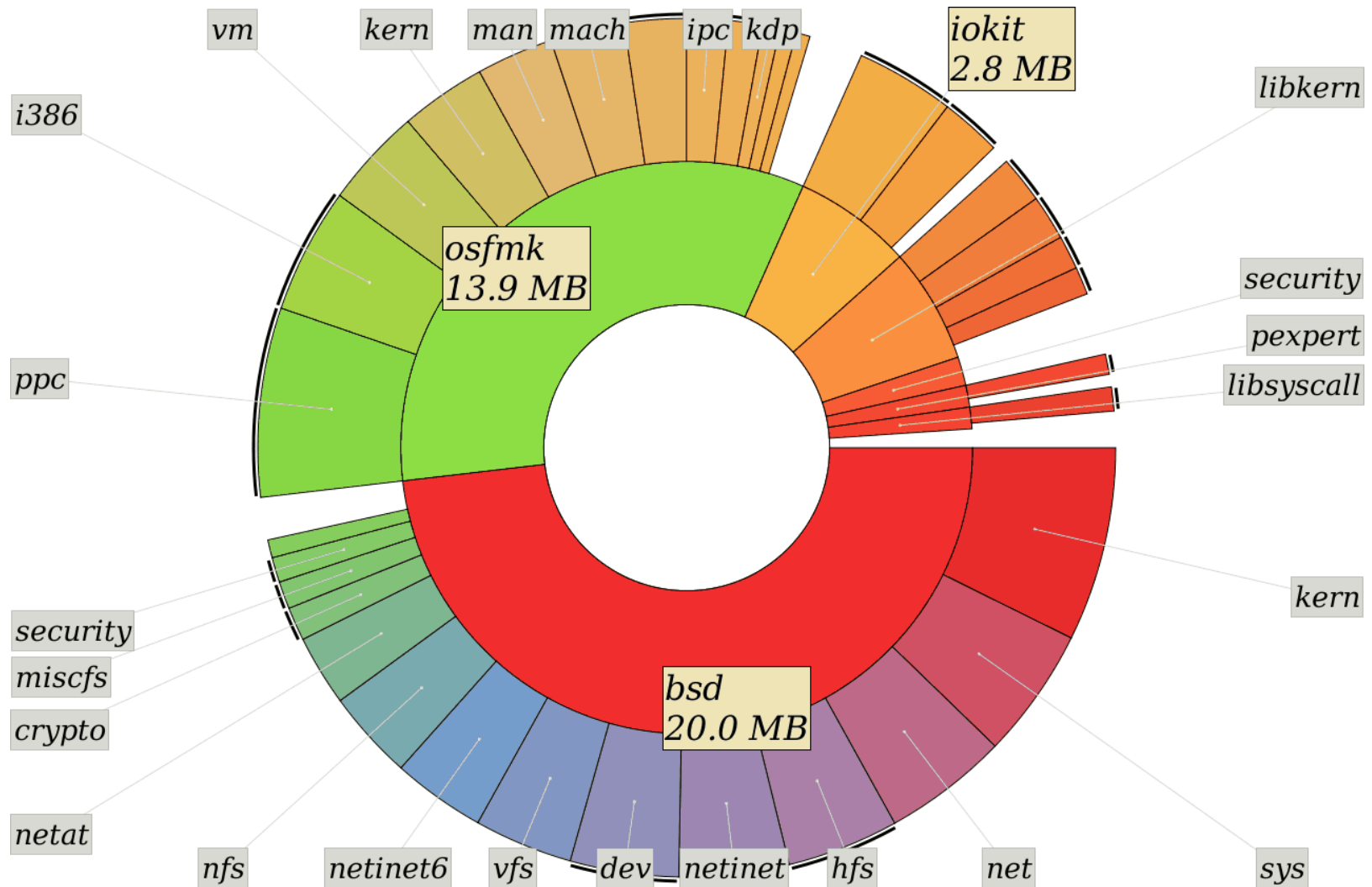

XNU kernel

- Type: Hybrid
- Mach + BSD
- Total source: 41.5MB
- SLOC: 726,171
- C: 85.33%
- cpp: 8.10%
- asm: 6.16%

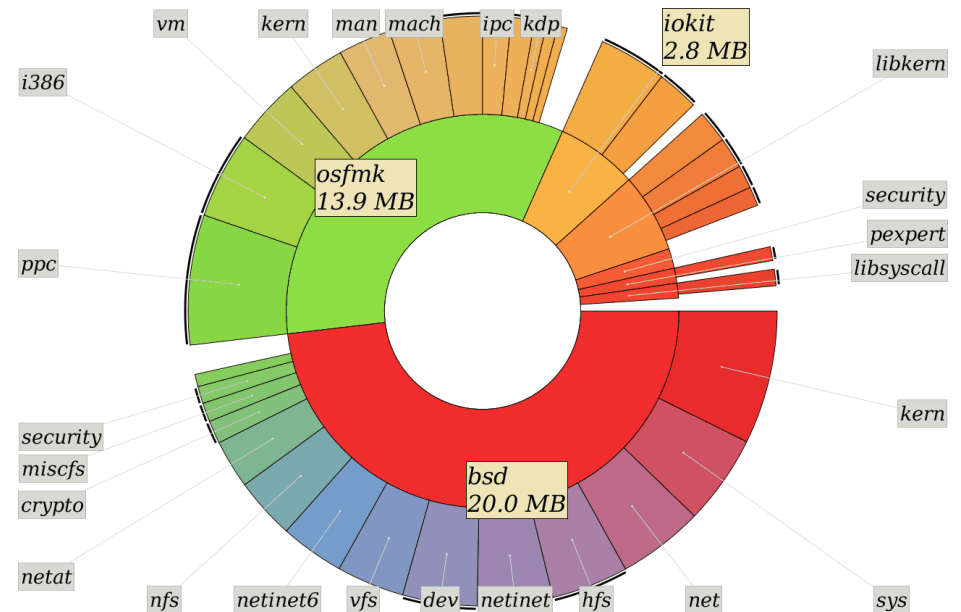

Darbat kernel

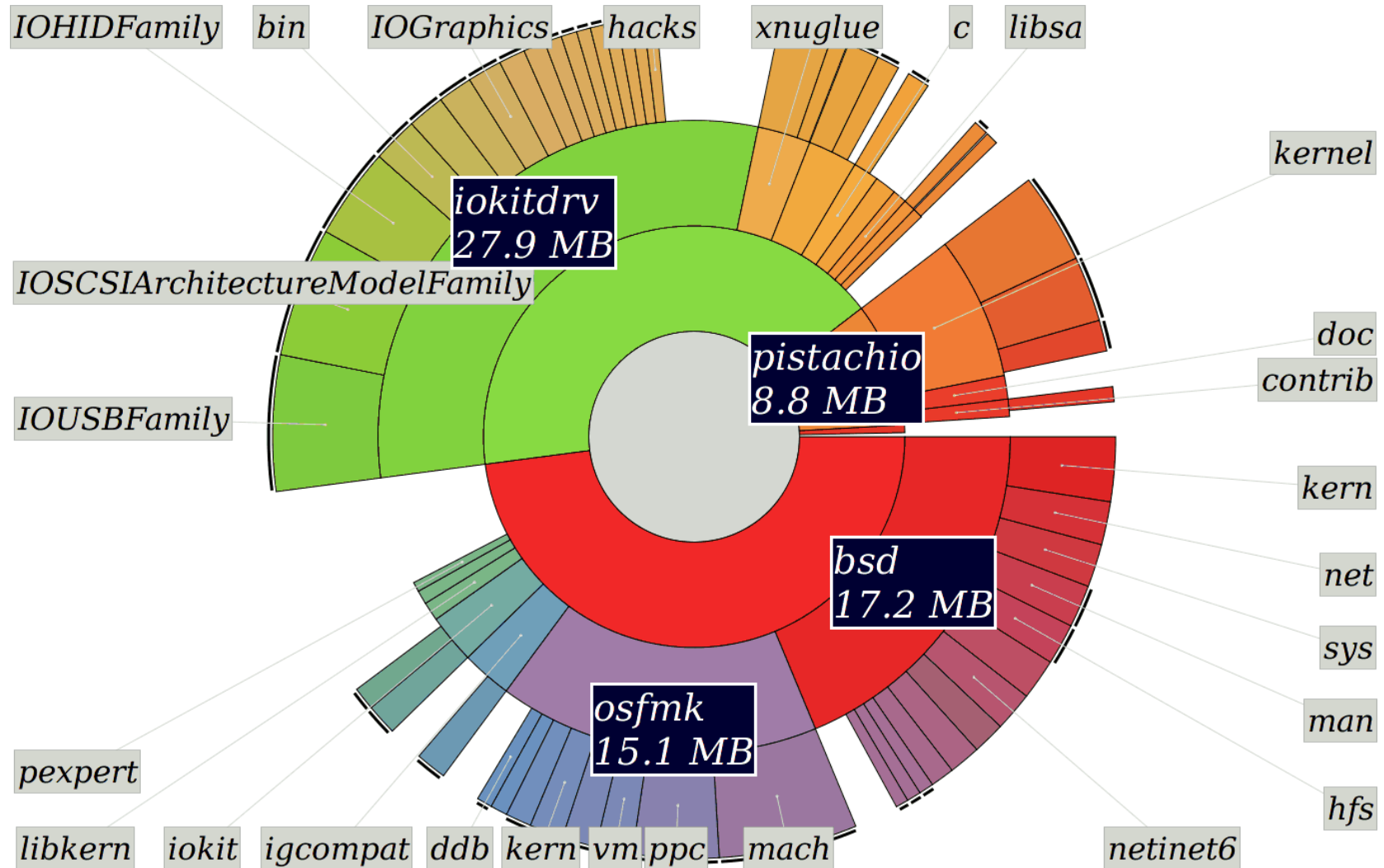

Darbat kernel

- Type: Hybrid
- L4 + XNU (*Mach* + *BSD*)
- Total SLOC: 1,133,598
- C: 64.41%
- cpp: 29.77%
- asm: 4.26%

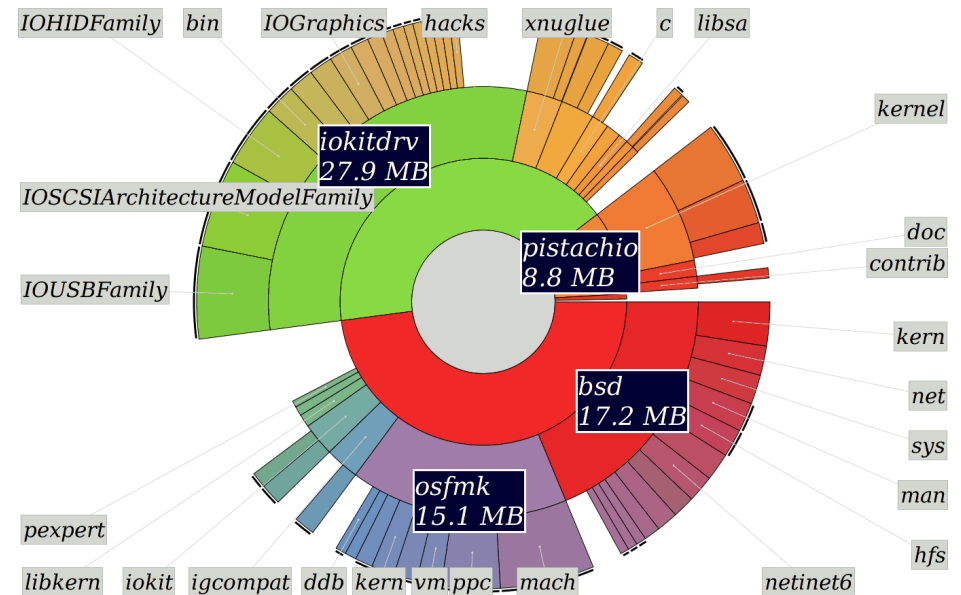

HP-UX kernel

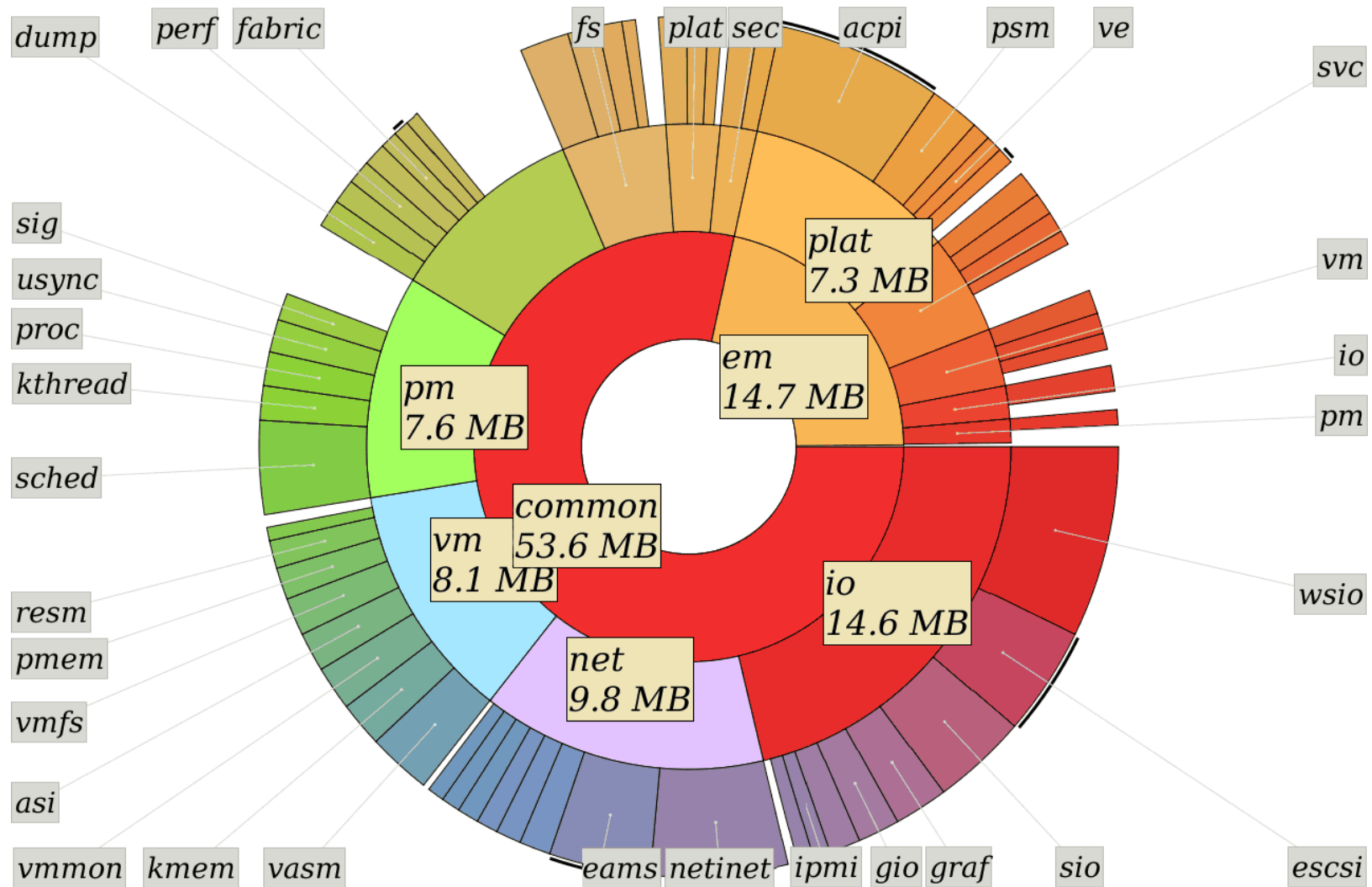

HP-UX kernel

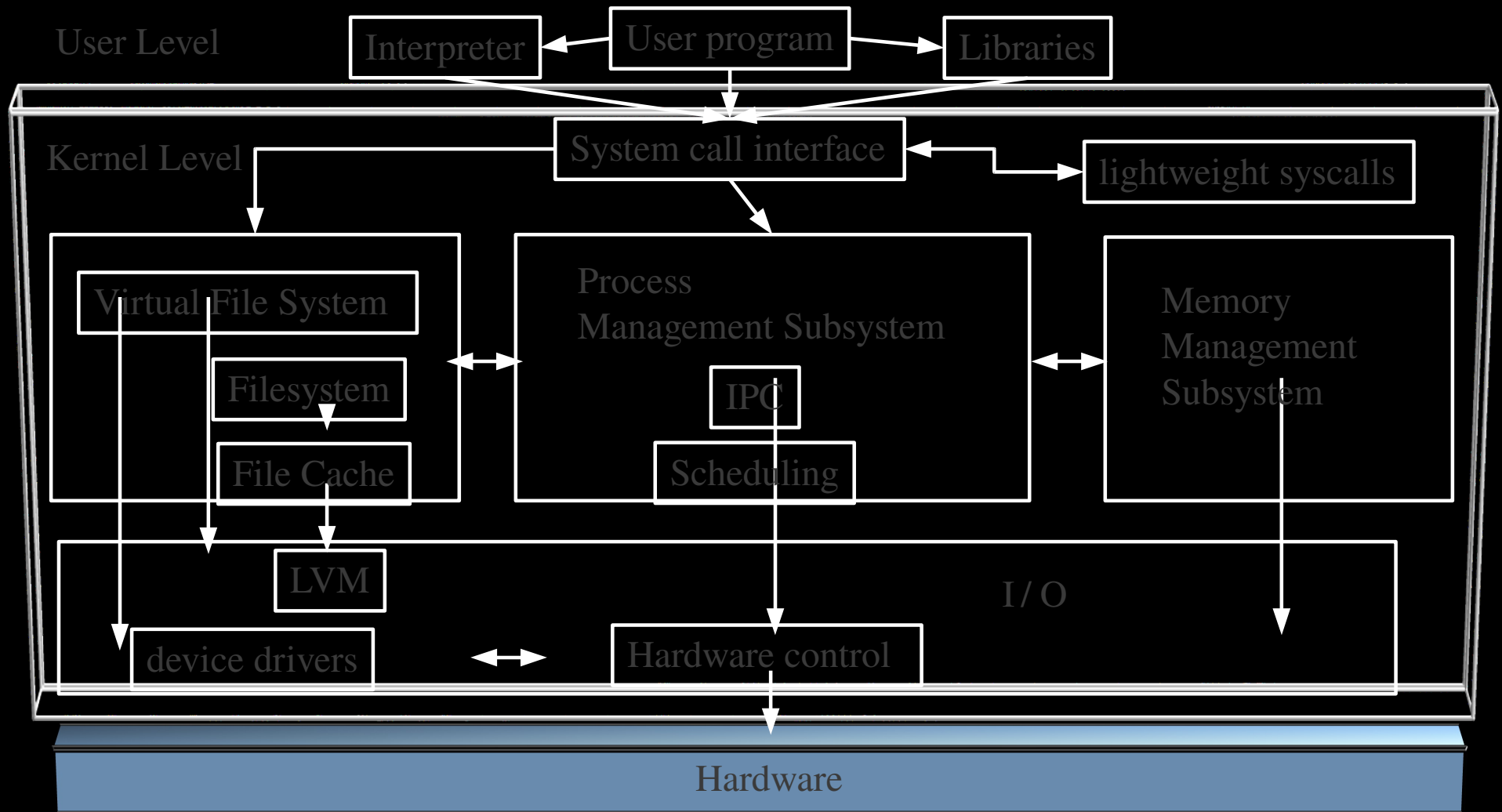

HP-UX kernel

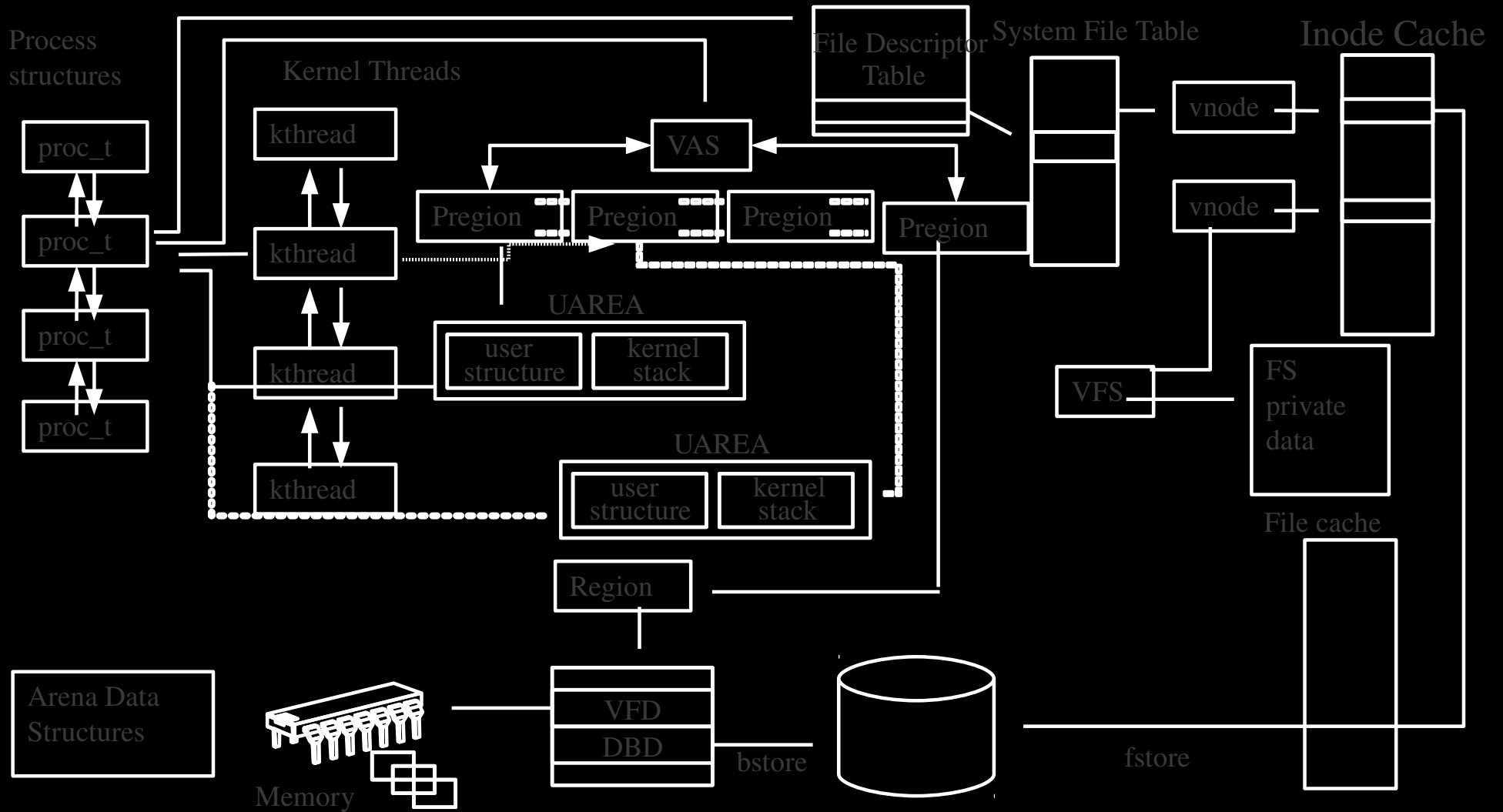

Tru64 kernel

Mach System Calls
by Select System Services

UNIX System Calls
by Applications

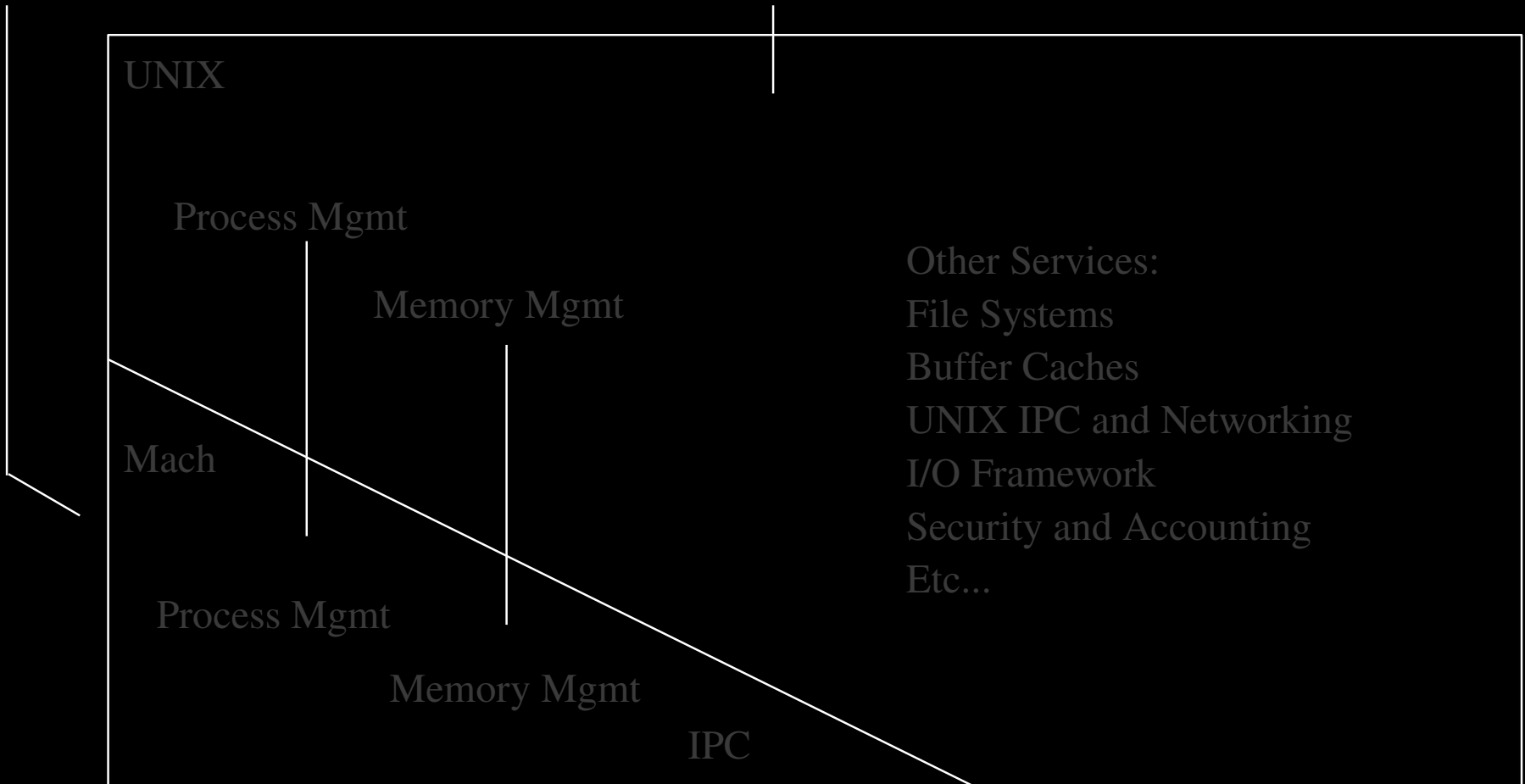

Tru64 kernel

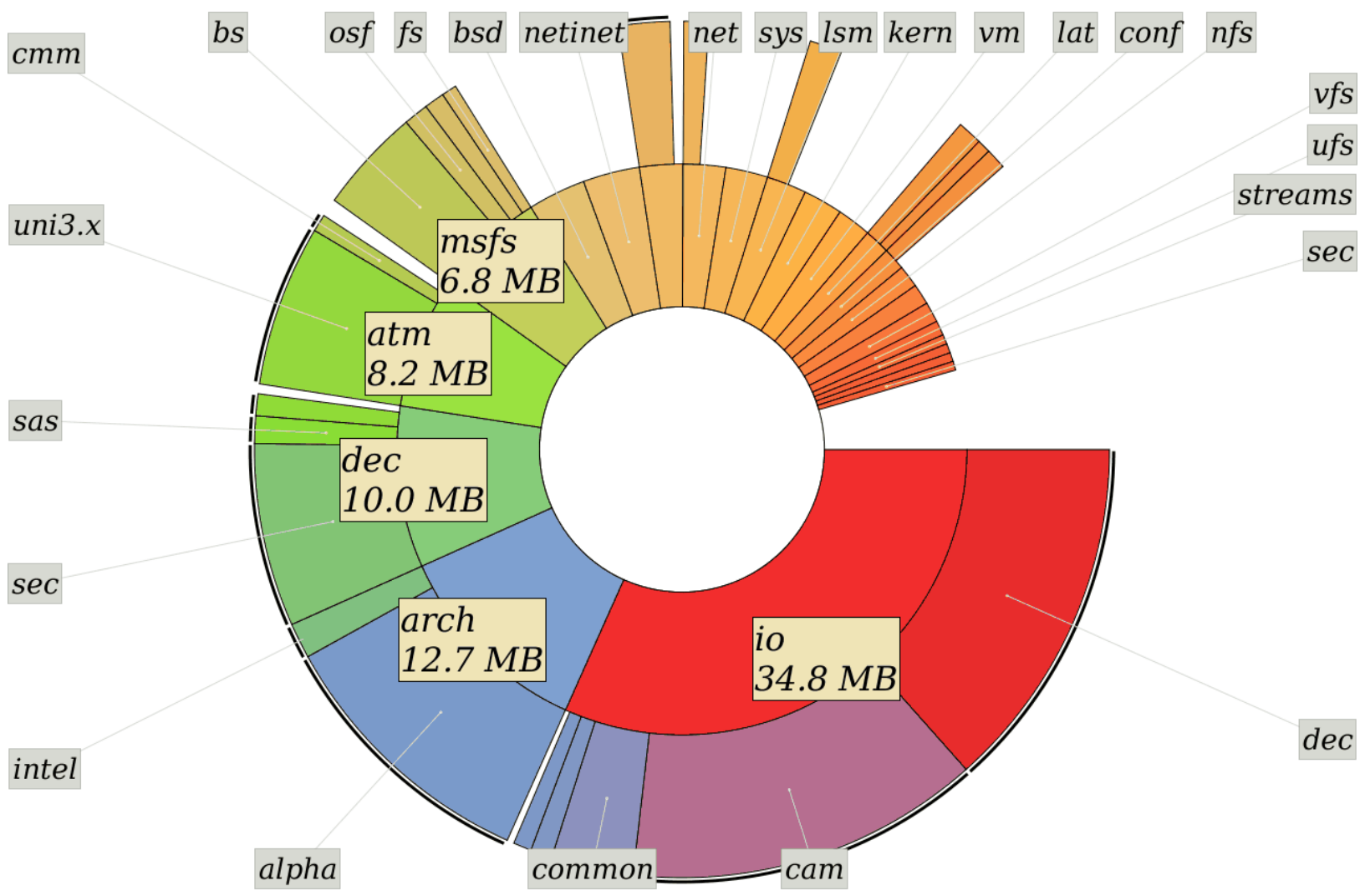

Tru64 kernel

- Type: Hybrid
 - Mach + UNIX
- Total source: 109MB
- SLOC: 1,562,952
 - C: 97.87%
 - asm: 1.76%

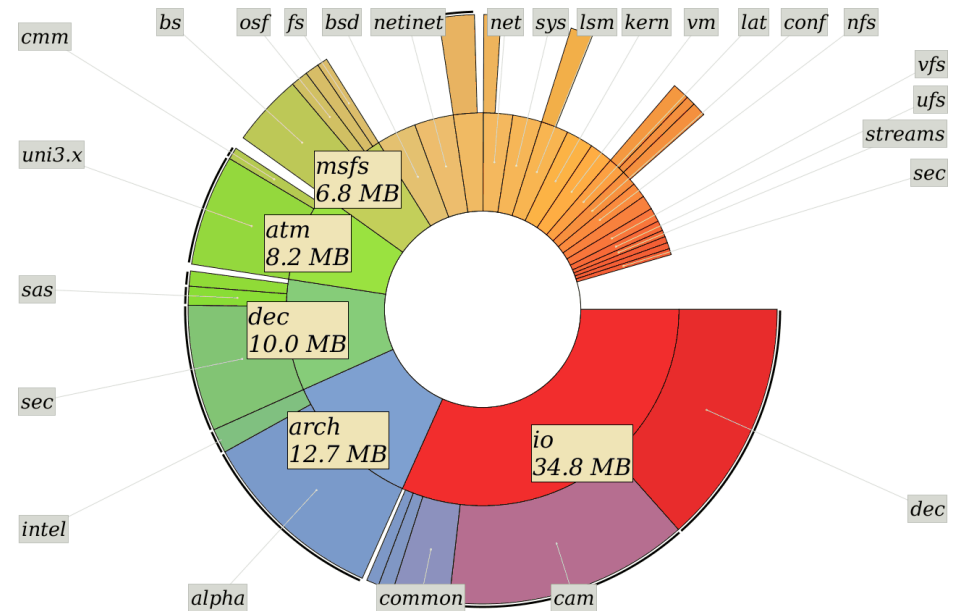

Tru64 kernel

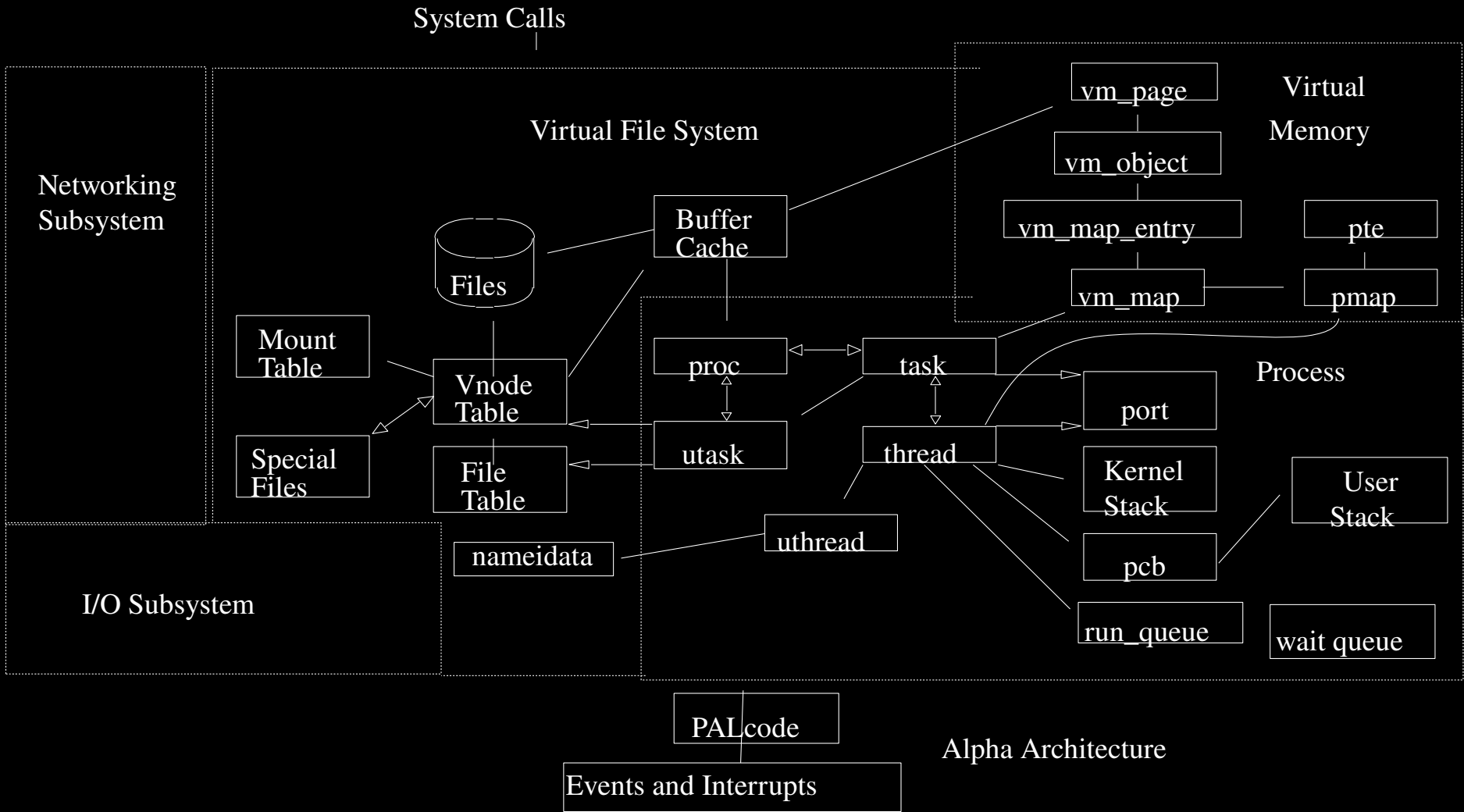

FreeBSD kernel

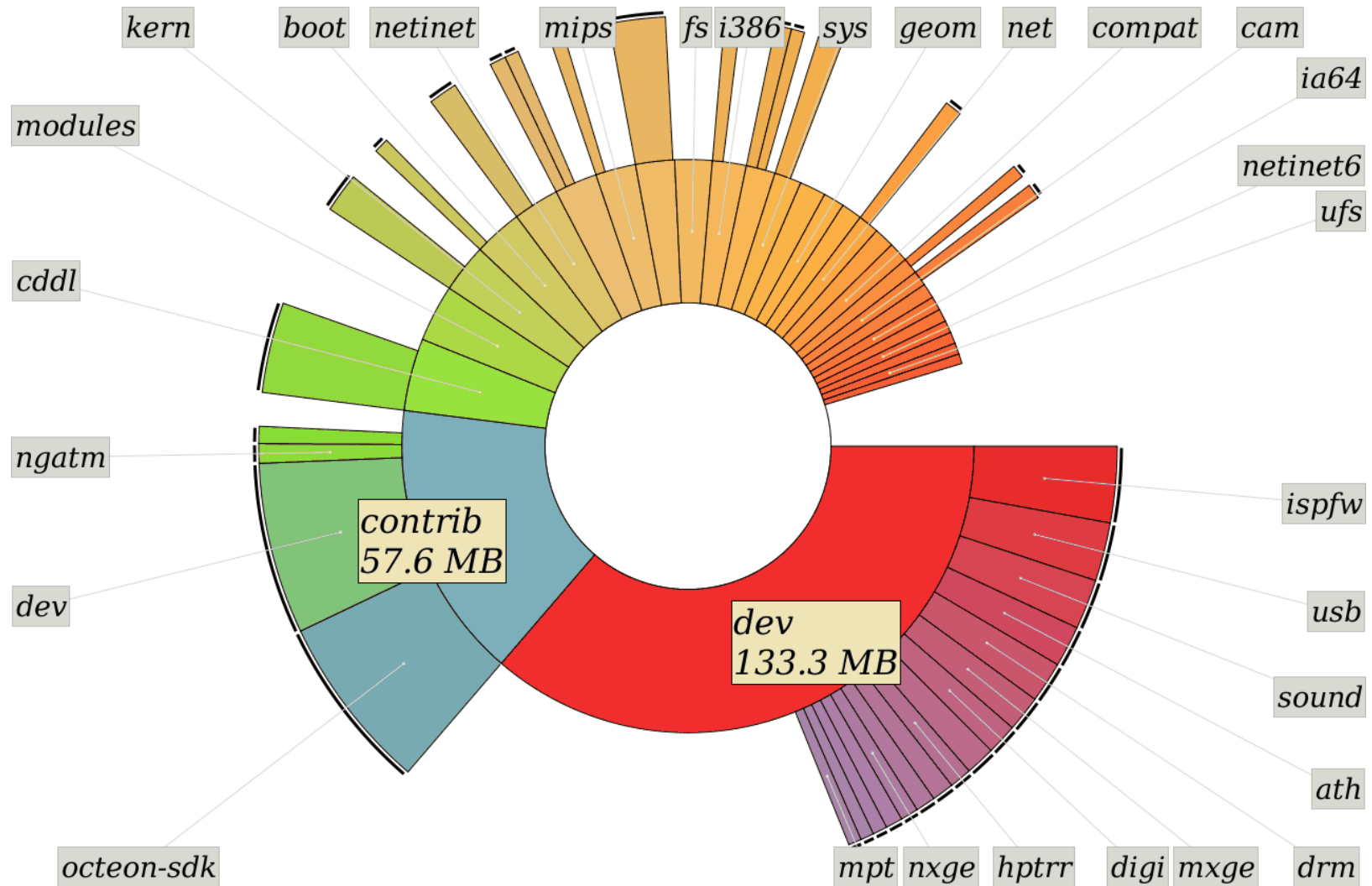

FreeBSD kernel

- Type: Monolithic
- Total source: 368.2MB
- SLOC: 3,058,571
- C: 98.03%
- sh: 1.61%

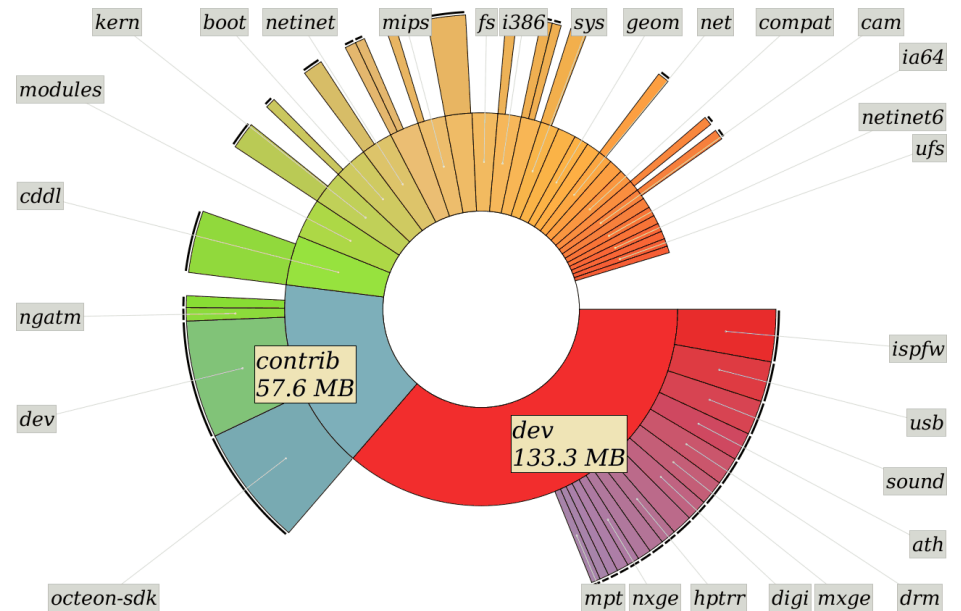

OpenSolaris kernel

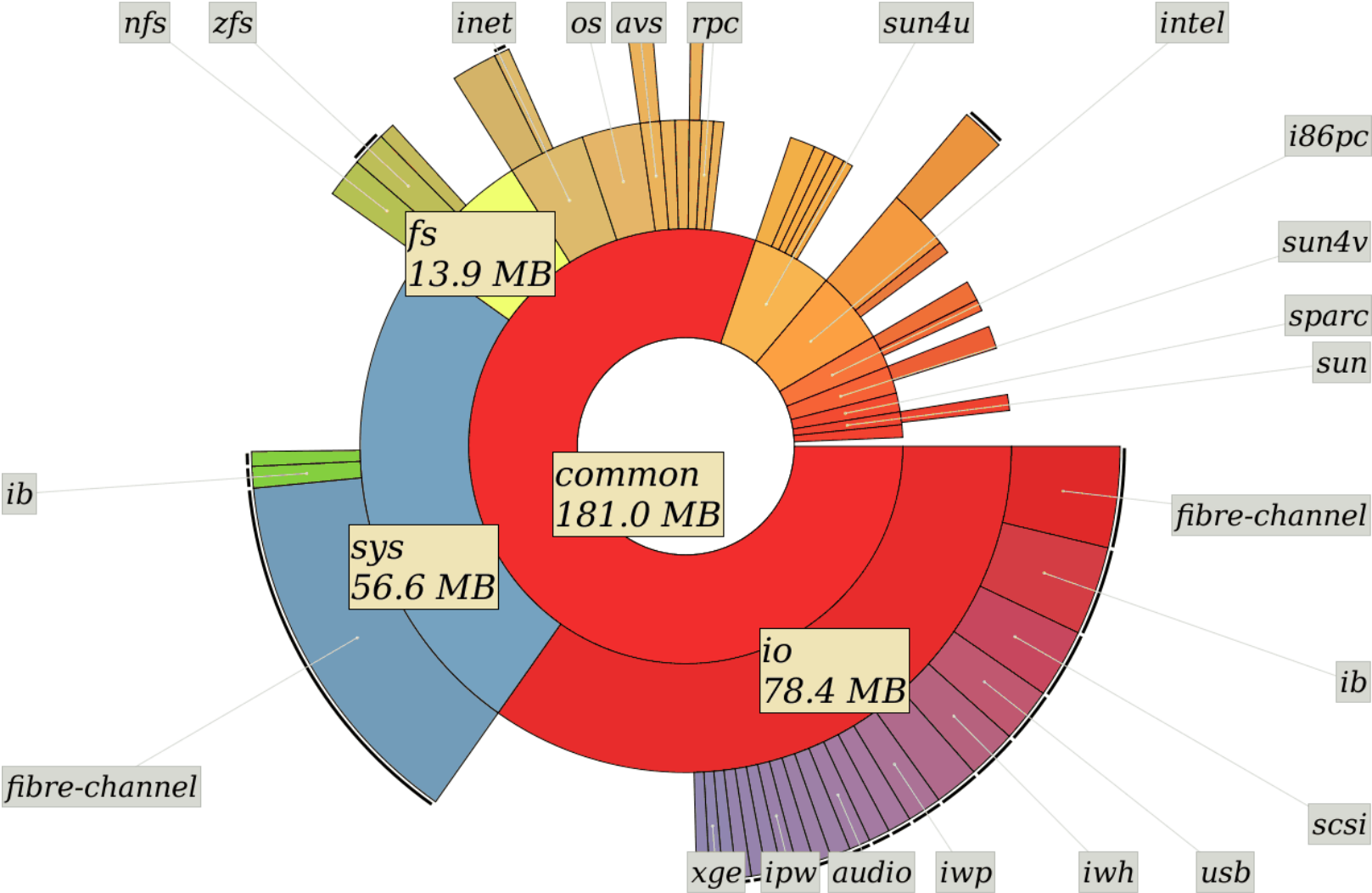

OpenSolaris kernel

- Type: Monolithic
- Total source: 226.1MB
- SLOC: 4,390,698
- C: 98.37%
- asm: 1.57%

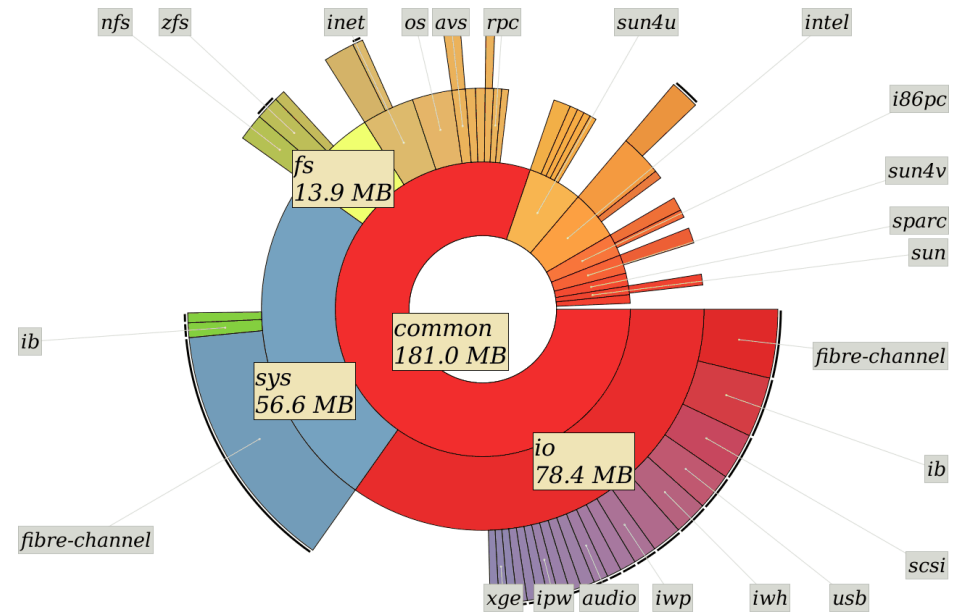

OpenSolaris kernel

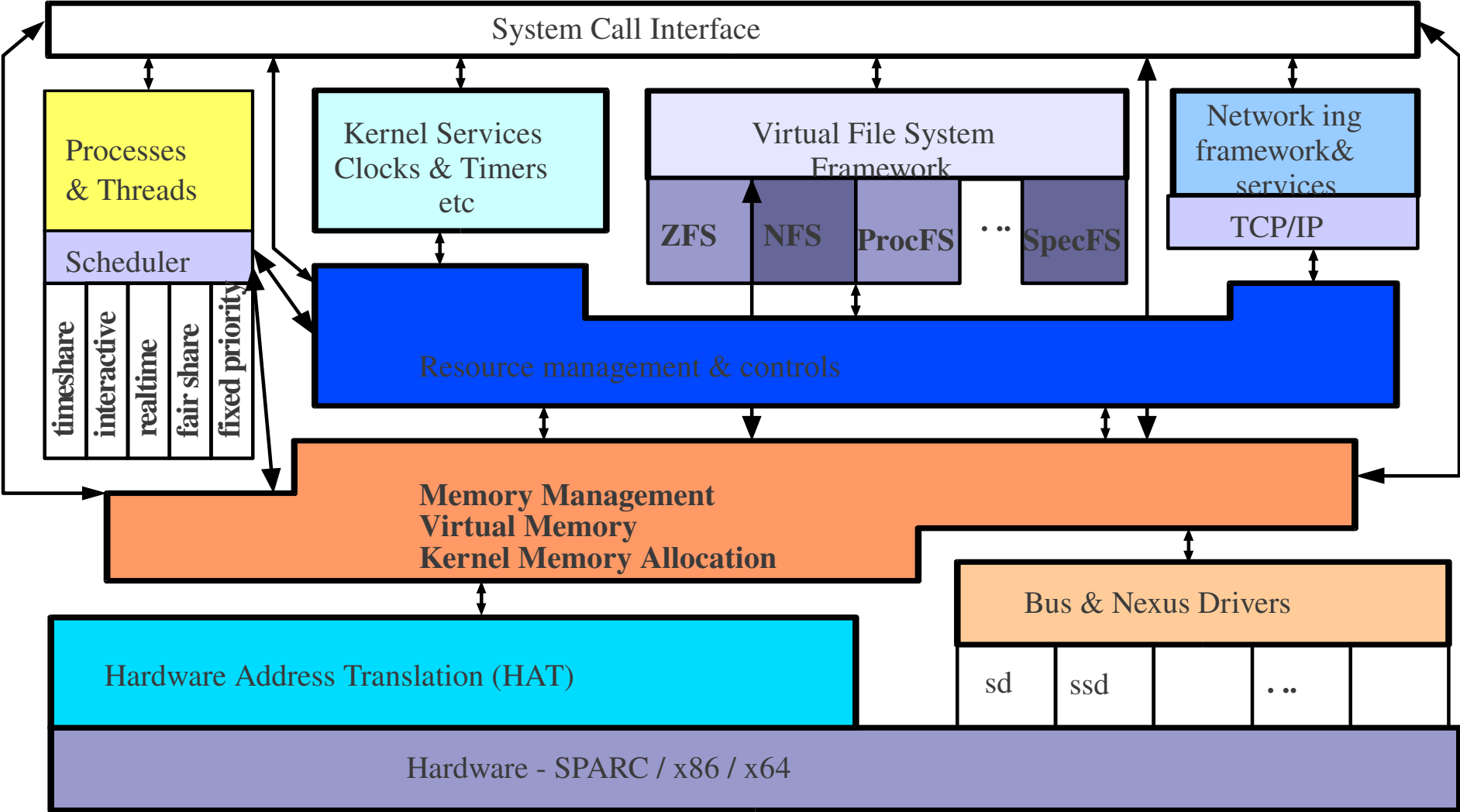

Others? (So many!)

- QNX
- Symbian
- DragonflyBSD

Linux kernel

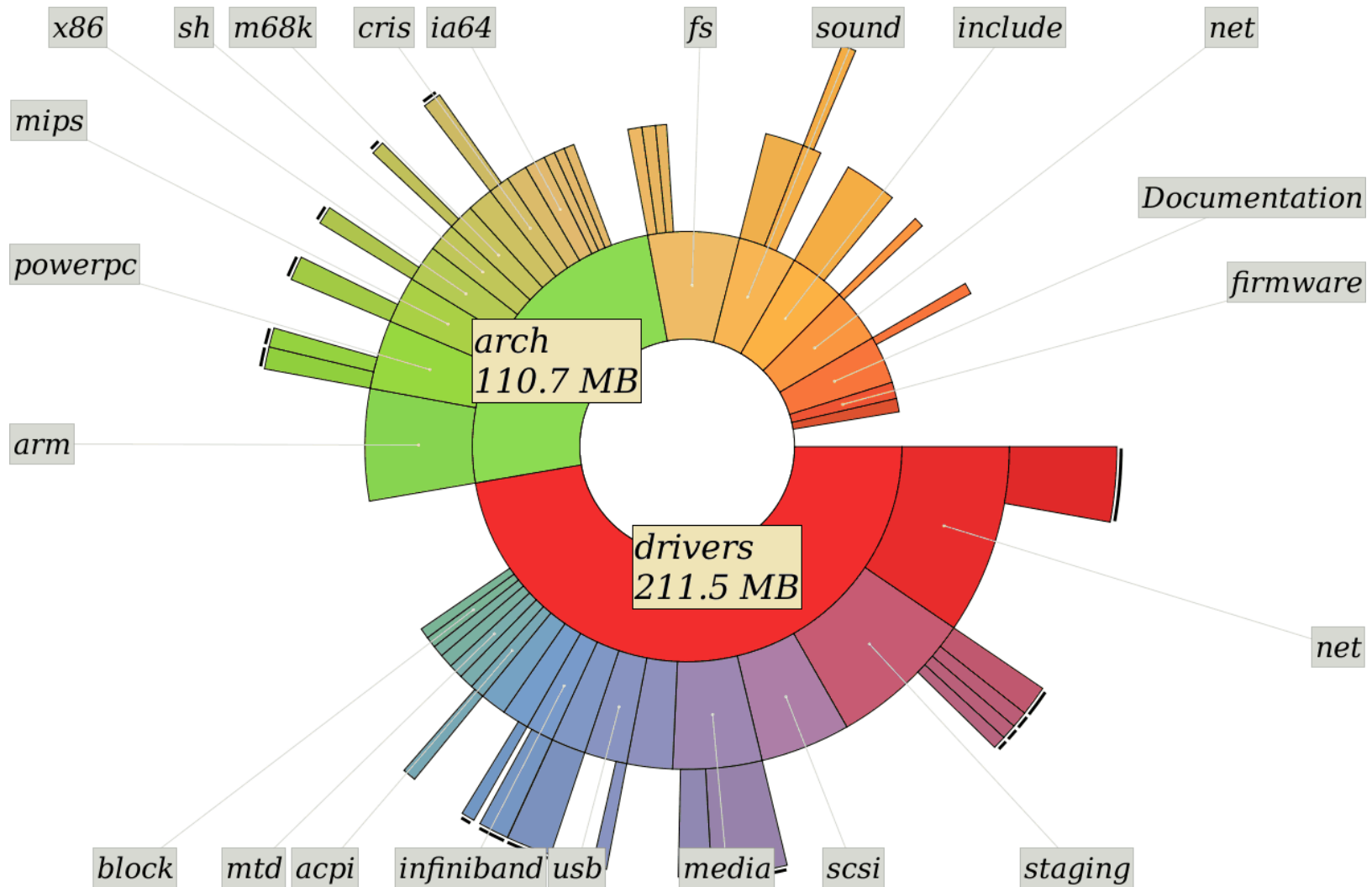

Linux kernel

- Type: Monolithic
- Total source: 413.4MB
- SLOC: 8,825,258
- C: 97.13%
- asm: 2.62%

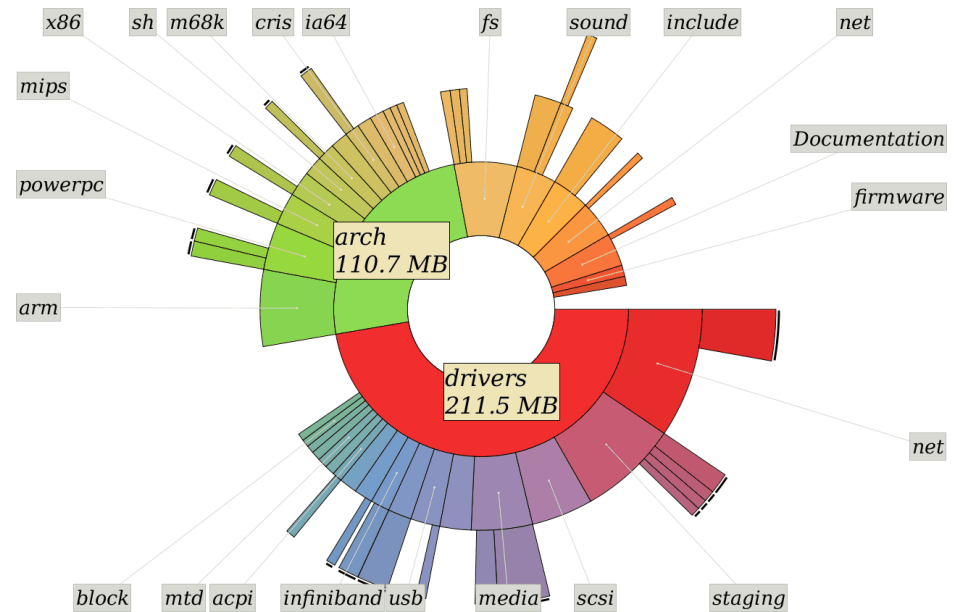

Linux kernel - my 6730b laptop's requirements

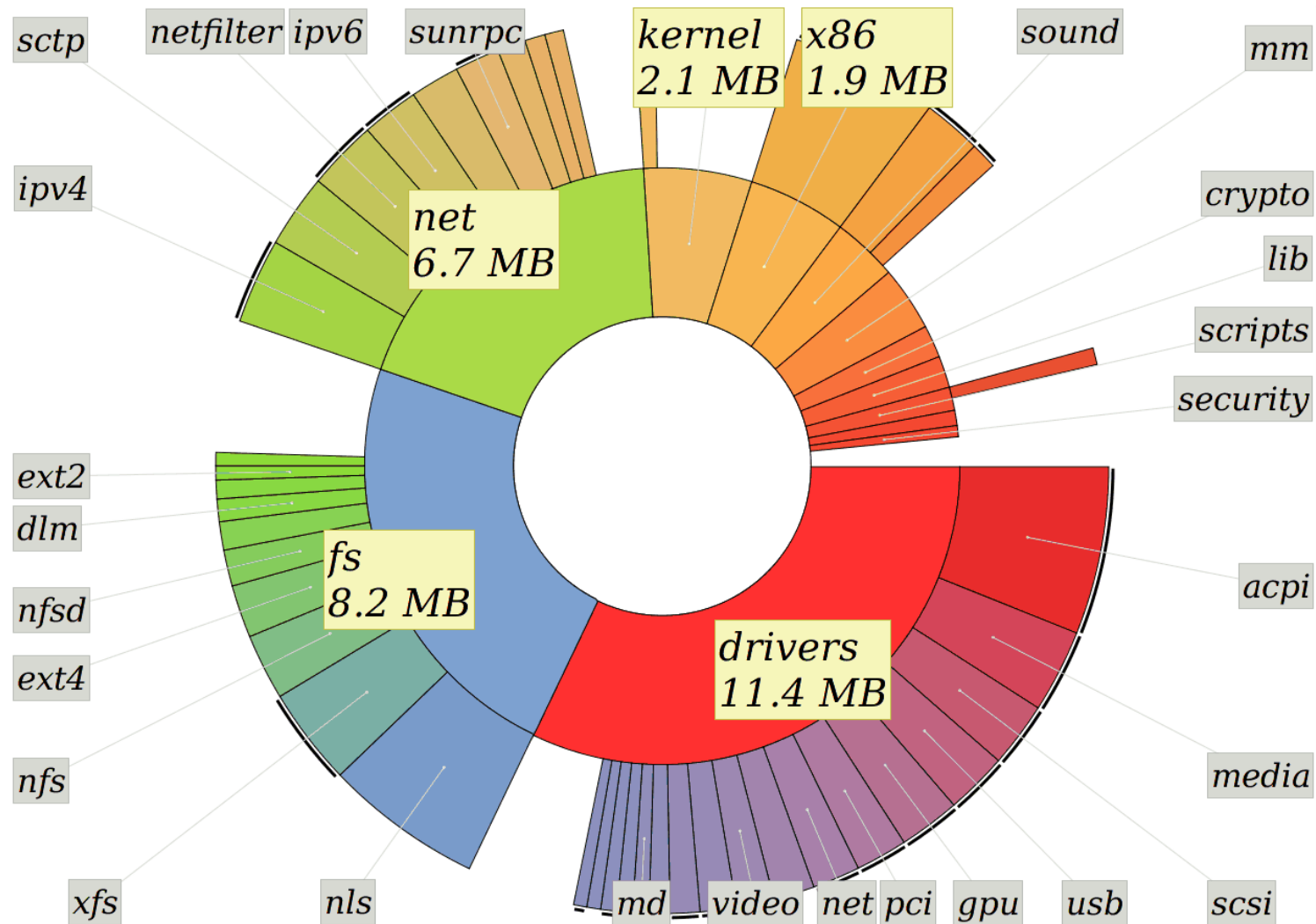

Linux kernel - my 6730b laptop's requirements

- Total source: 35.5MB
- SLOC: 889,598

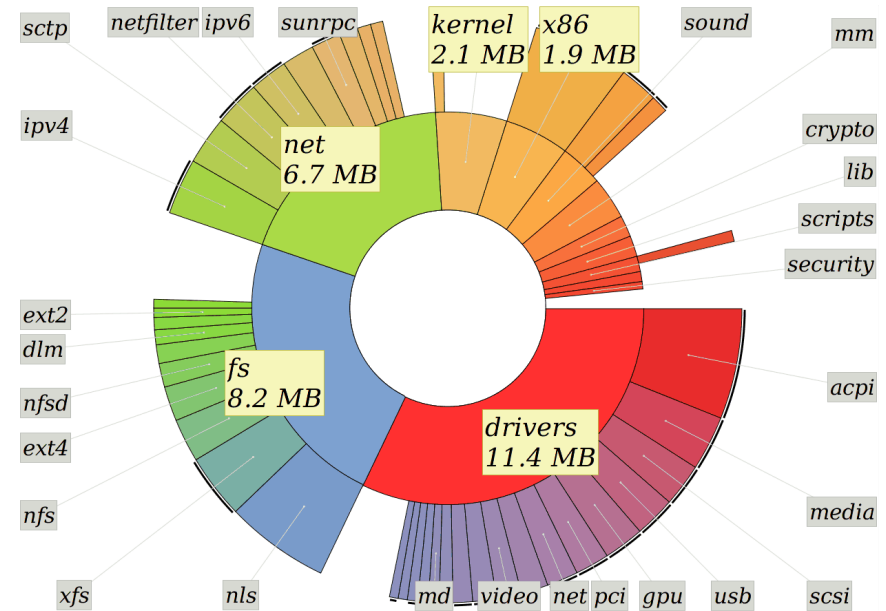

Linux kernel - core functionality

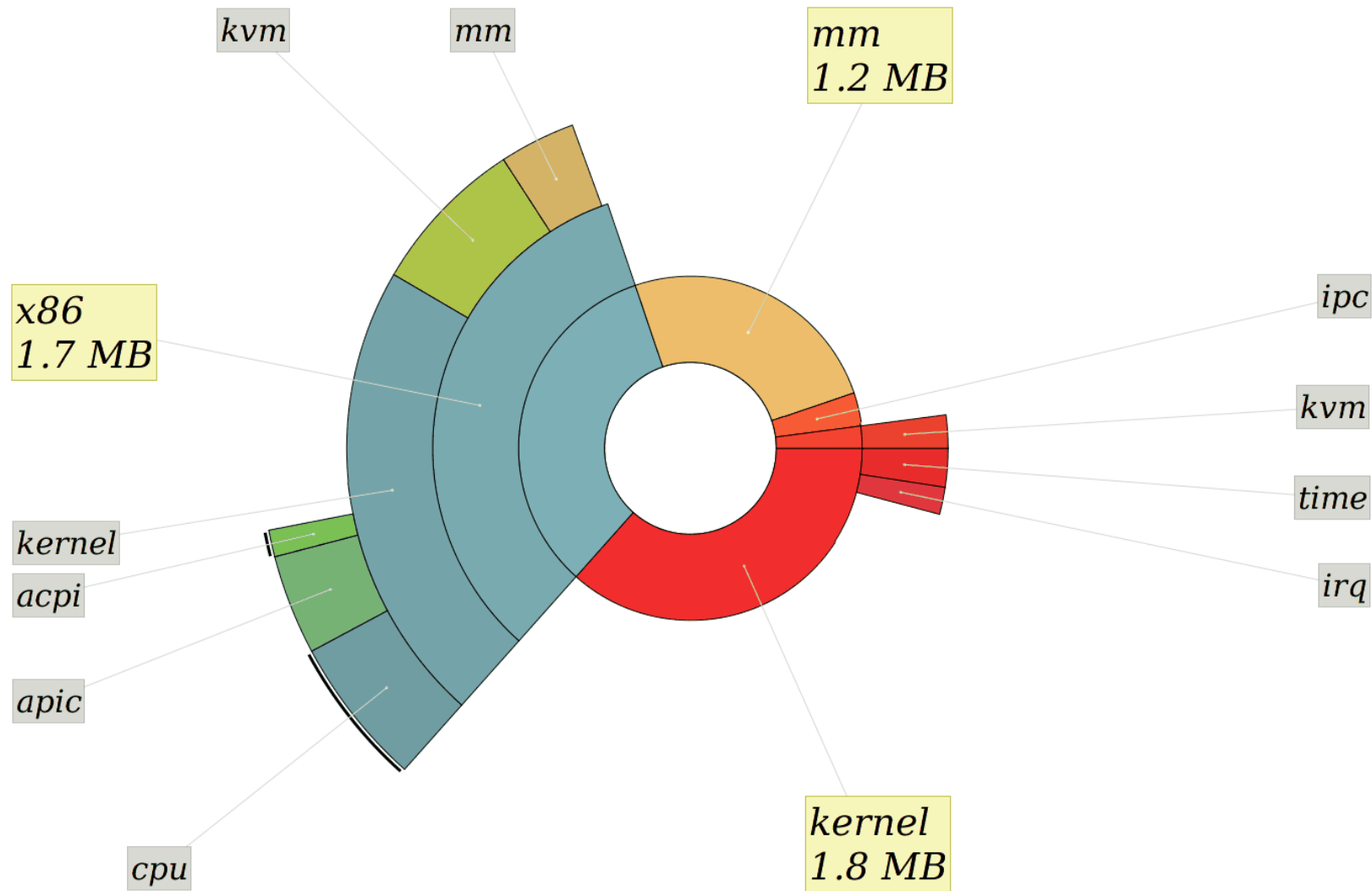

Linux kernel - core functionality

- Total source: 5.0MB
- SLOC: 134,080

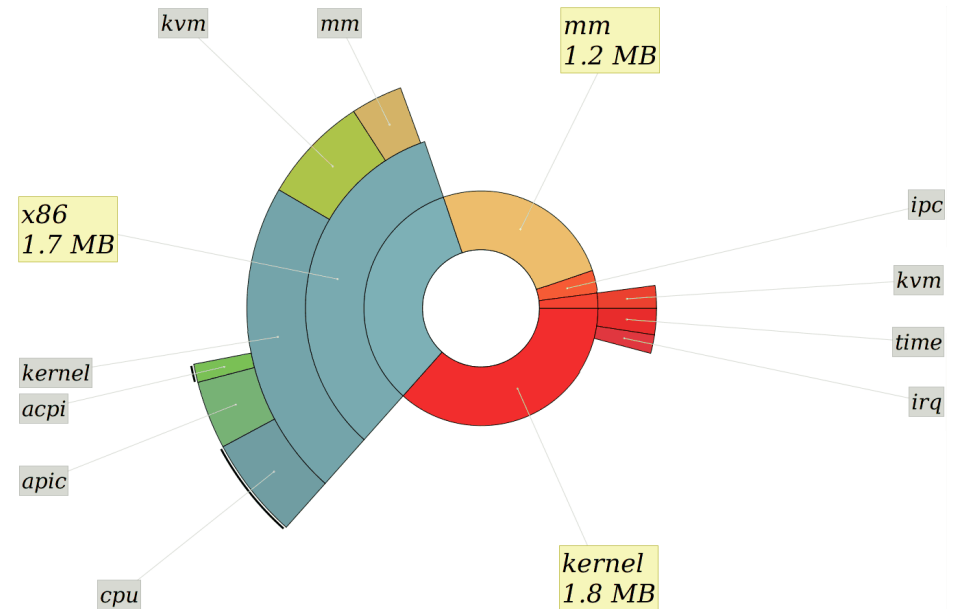

Linux - *kernel*/

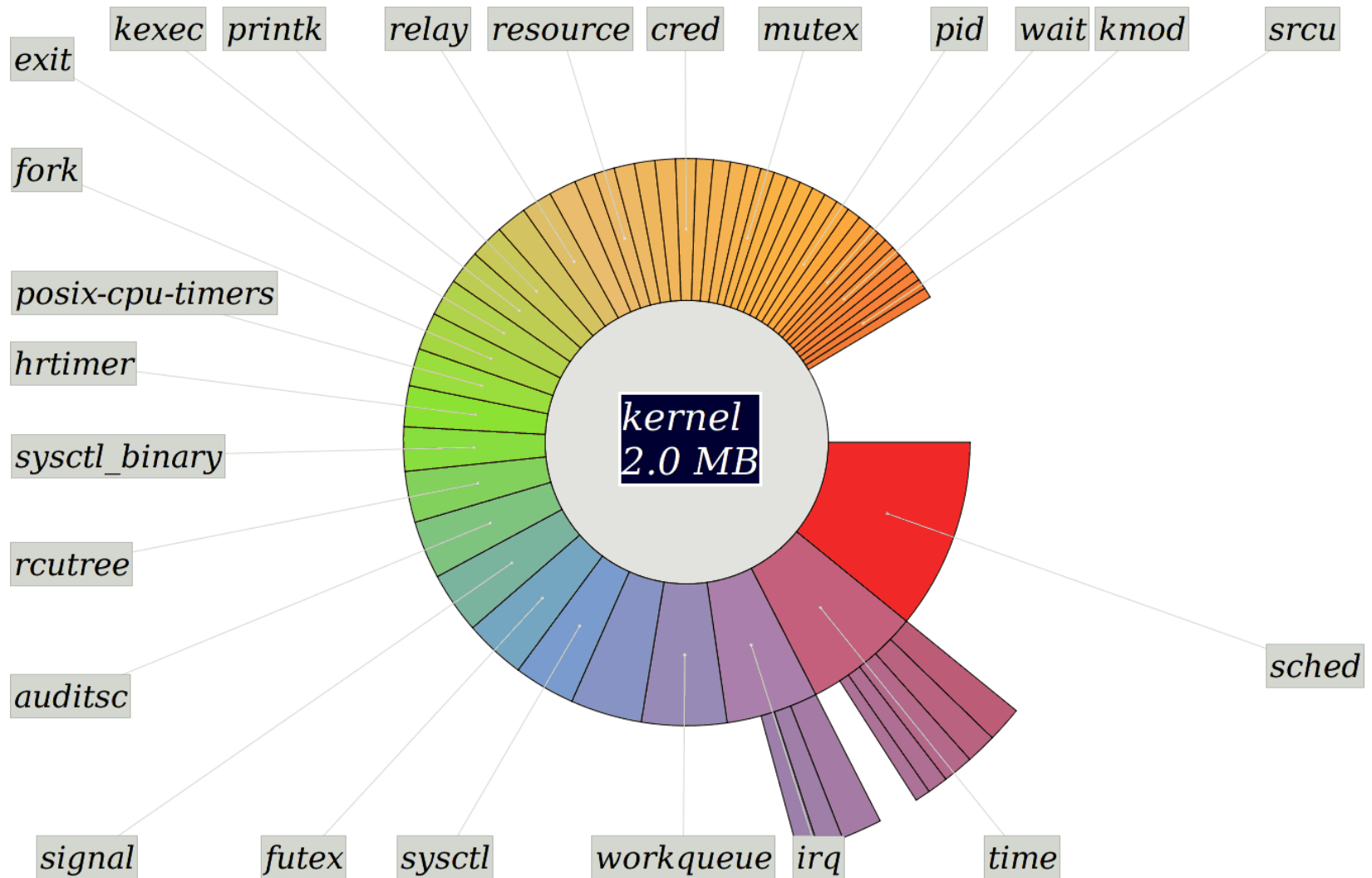

Linux - *arch/x86/*

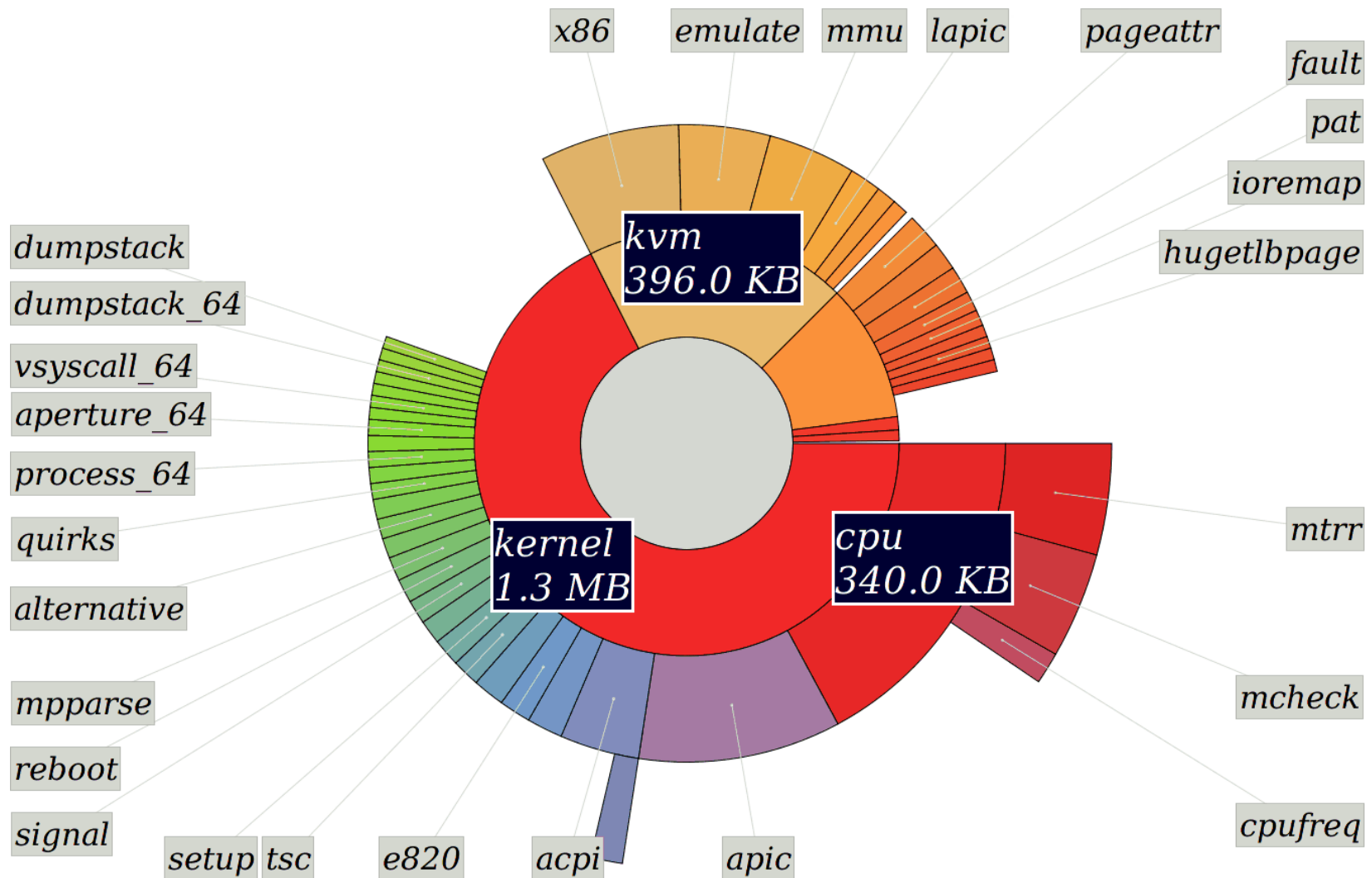

Linux - *mm/*

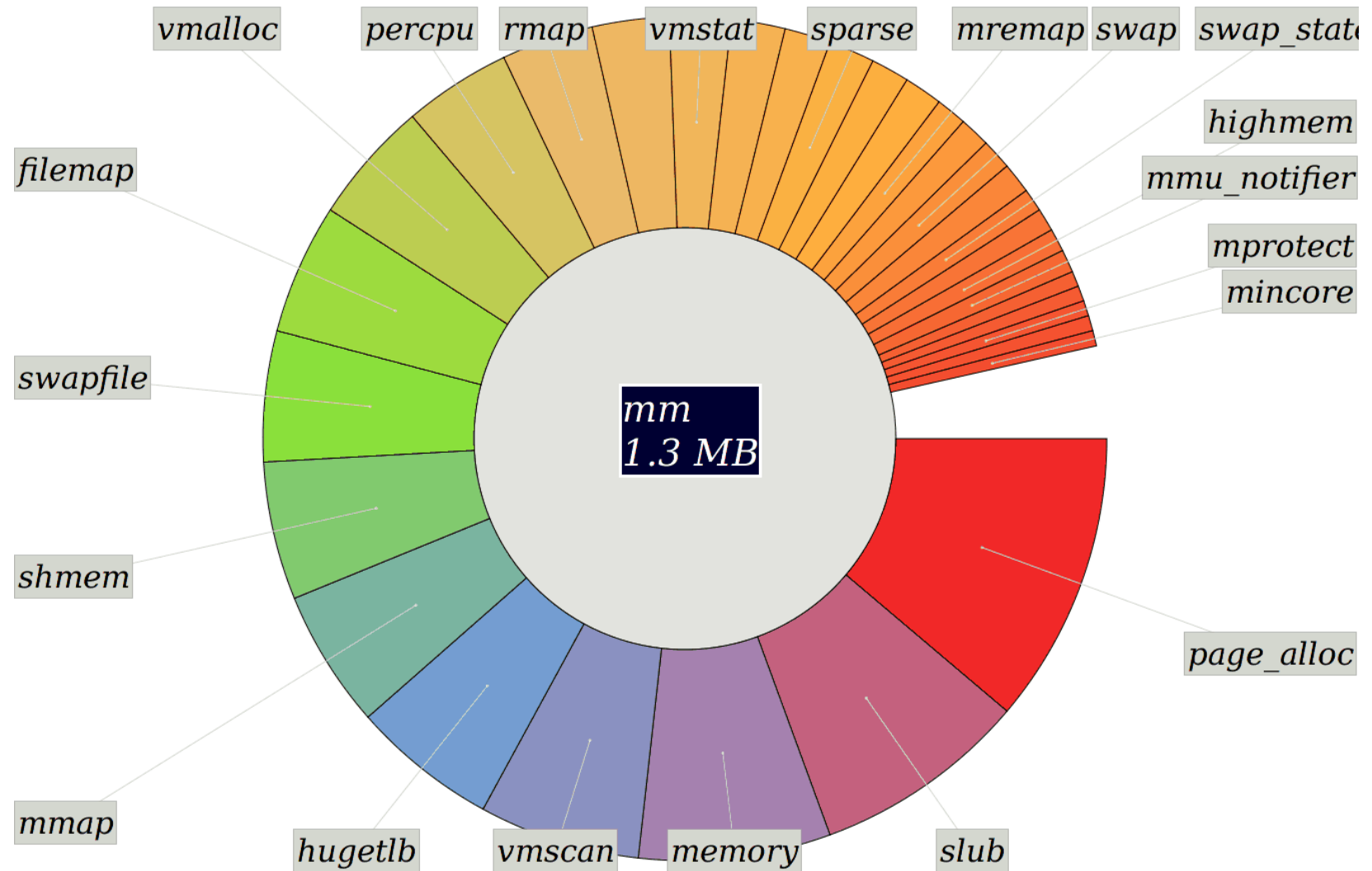

Linux - *ipc/*

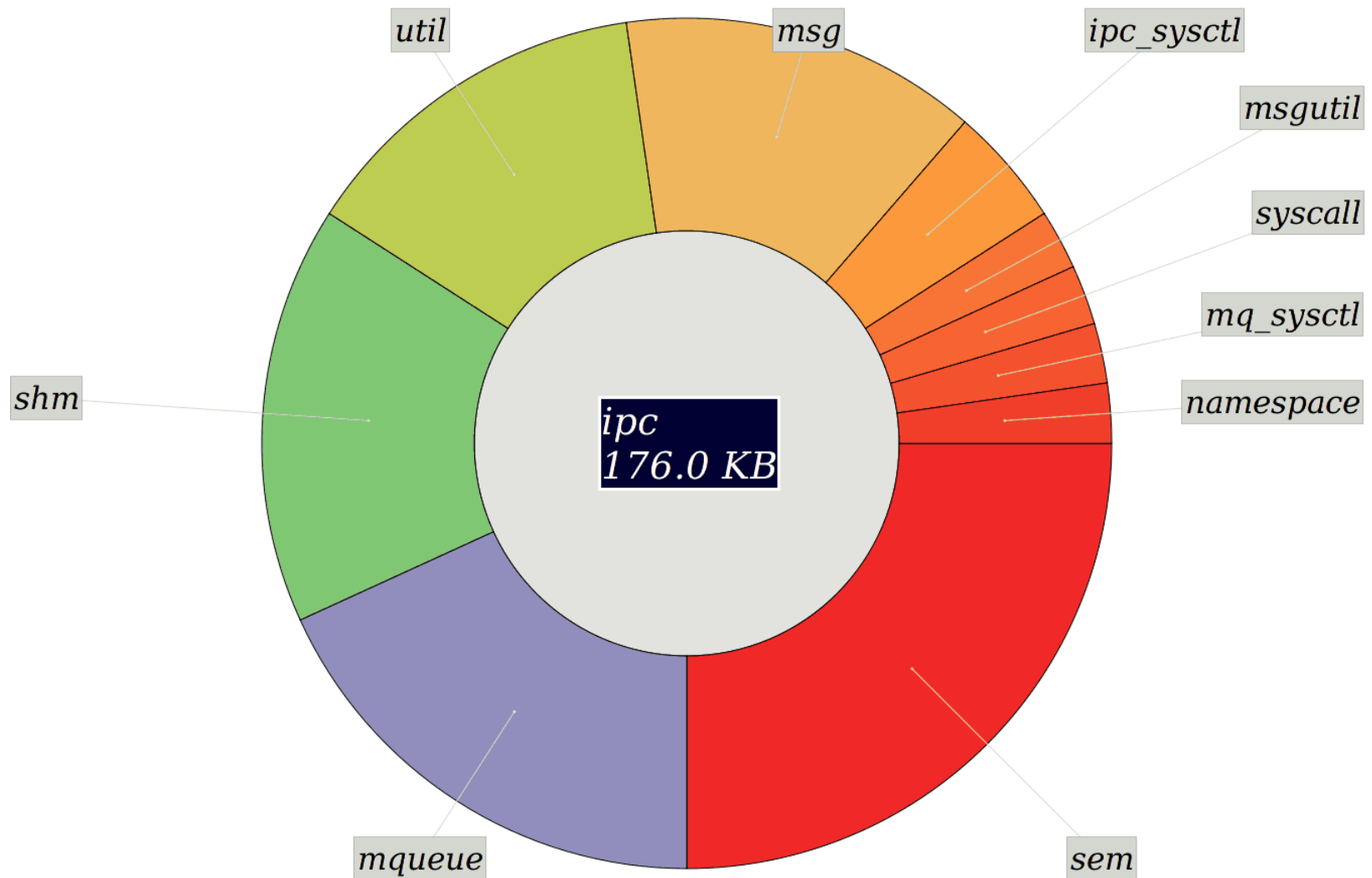

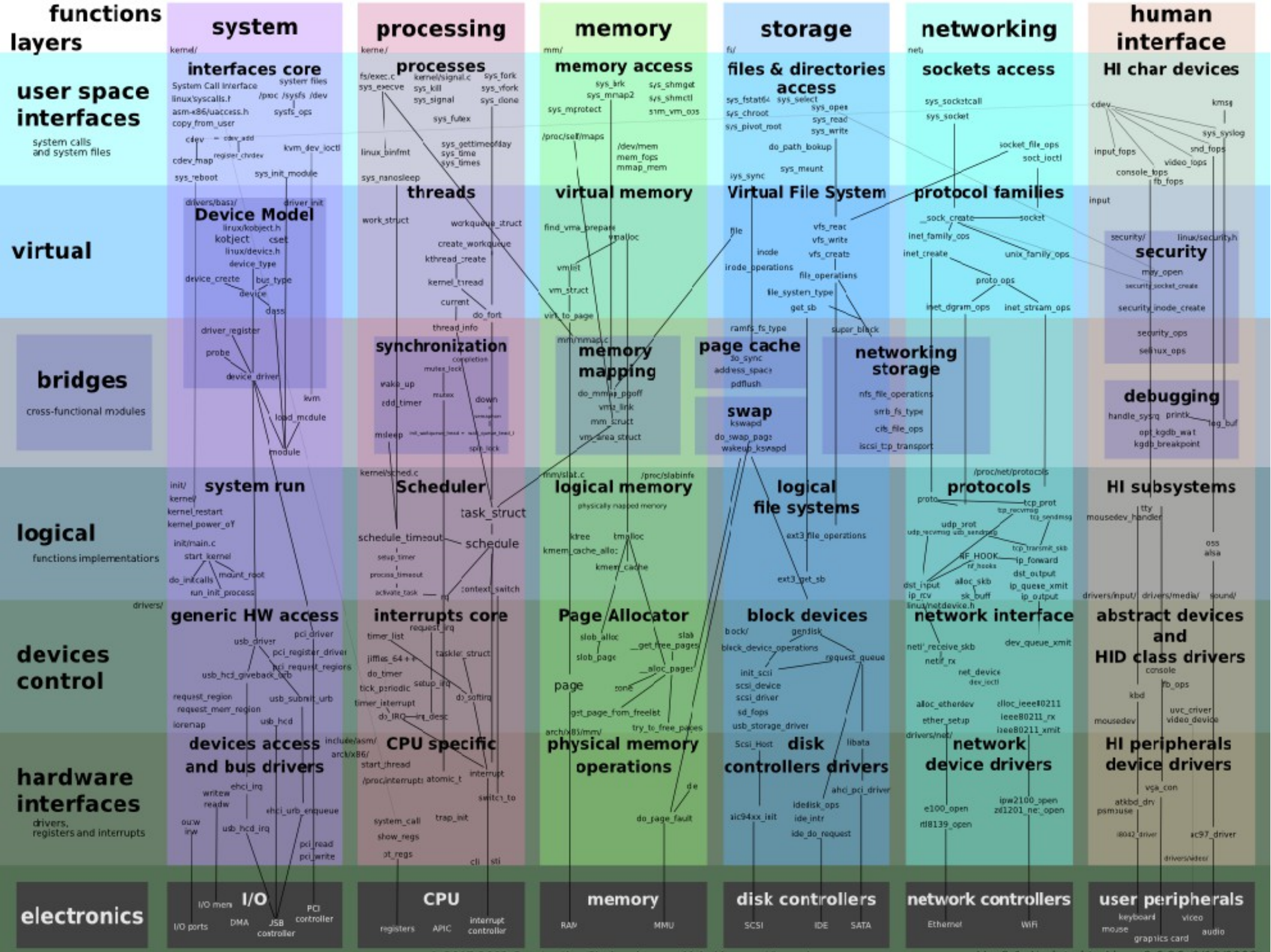

Thank

you